



- Torque-speed characteristics
- Determination of motor parameters - inertia and friction
- Digital display of time constant
- Transfer function evaluation

### Introduction

A d.c. motor is commonly used as an actuator in many industrial control applications because of its features - large torque and ease of speed variation. The dynamic characteristics of such a system therefore depends on the motor parameters viz., Moment of inertia, coefficient of friction, time constant and also the resistance and inductance of the control winding. It is therefore important to experimentally determine the mechanical and electrical parameters of the d.c. motor and also to evaluate its transfer function.

The present unit is designed to study a small permanent

magnet d.c. motor. A still smaller generator directly coupled to the motor is used for the dual purposes of speed signal pick up and providing electrical loading. The shaft speed in rpm is displayed automatically on a 4-digit panel meter.

When the motor is suddenly switched ON a novel circuit computes and displays the time constant in milliseconds on a 3-digit panel meter. This avoids the need for an expensive storage CRO. The motor unit is housed in a cabinet with transparent panels, providing a good view of the mechanical system.

### Experiments

- Torque-speed characteristics
- Inertia and friction parameters
- Back e.m.f. constant
- Time constant
- Transfer function

### Features and Specifications

- Study of a 12V, 8W d.c. motor
- Small generator (2W) for speed pick up and loading
- 4-digit speed display
- 3-digit time constant display
- 3½ digit voltmeter and current meter for d.c. measurement
- IC regulated power supply
- Supporting literature with experiment details



Note: Specifications are subject to change.

### **Tesca Technologies Pvt. Ltd.**

305, Taru Chhaya Nagar, Tonk Road, Jaipur-302029, India  
Tel: +91-141-2724326, Mob: +91-9413330765  
Email: info@tesca.in, tesca.technologies@gmail.com  
Website: www.tesca.in

### Schematic Diagram

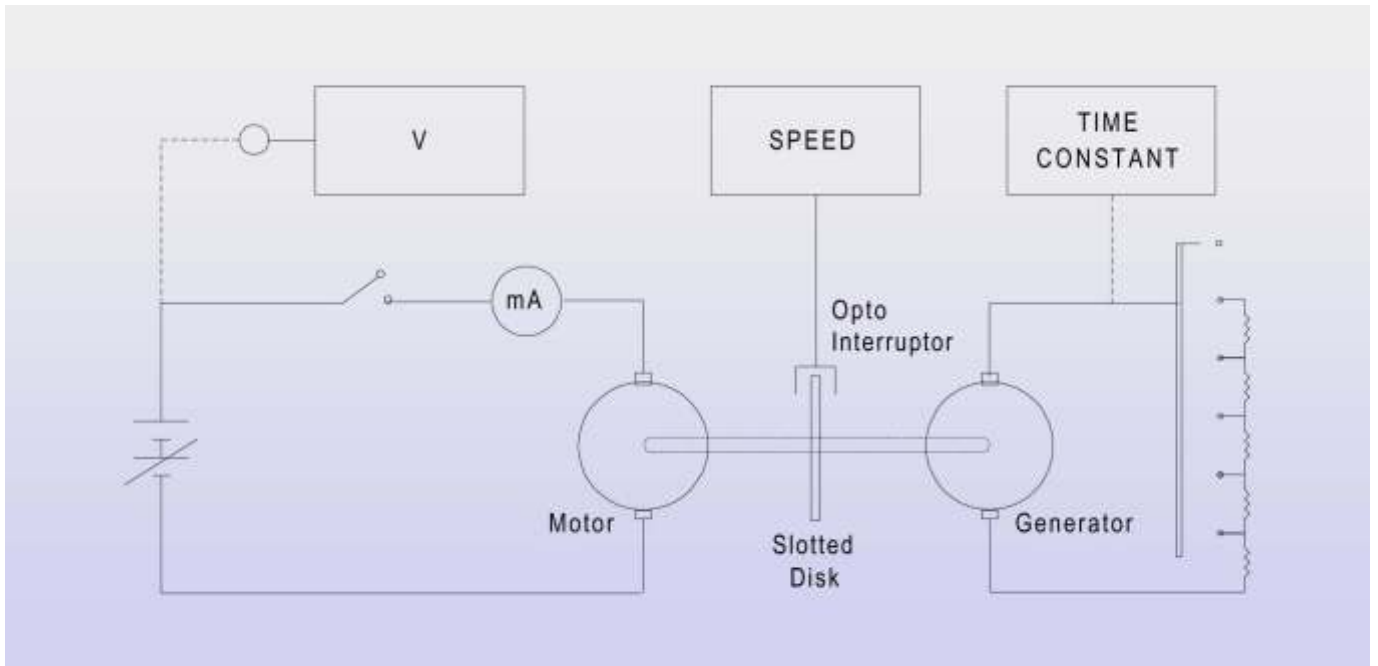

Note: Specifications are subject to change.

**Tesca Technologies Pvt. Ltd.**

305, Taru Chhaya Nagar, Tonk Road, Jaipur-302029, India

Tel: +91-141-2724326, Mob: +91-9413330765

Email: info@tesca.in, tesca.technologies@gmail.com

Website: www.tesca.in

