

Tesca Advanced Refrigeration Trainer 32402 is designed to provide students with a thorough understanding of various types of systems used in commercial and industrial applications. It permits students to understand the refrigeration cycle, including measurement of pressure, vacuum, flow rate and temperature.

The unit contains a reversing valve so that the system may be run as a heat pump in addition to operate as a refrigeration system.

Sight glasses at inlet and outlet of evaporator and condenser allows students to monitor changes in refrigerant state.

The system components are panel mounted to provide easy access for testing and troubleshooting. Incorporated two type of evaporator i.e. air cool type & water source type, it enables the study of compressor's COP, through P - H Diagram Investigation & heat balance.

List of Experiments for Degree & Higher National Diploma Level

- Familiarization with various types of compressor
- Investigation on the operation of the compressor
- Study of COP calculation in Refrigeration Cycle
- Study of Pressure and Heat Analysis Diagram
- Familiarization with the operating of metering devices, for instance, thermostatic expansion valve, manual throttle valve, capillary tube
- Study on system control devices such as temperature controllers, thermostatic controls, solenoid valve Reverse Valve Heat Pump controls and backpressure regulator
- Study on the principles of evaporator and condenser superheating and sub cooling, heat exchanger
- Investigation of refrigeration system

RT25 component layout

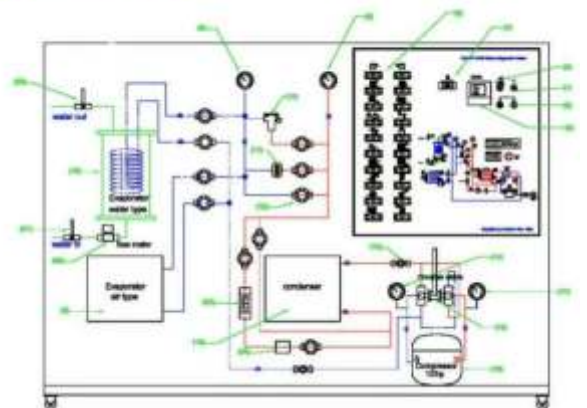

List of Experiments Basic skill training

- Basic function of refrigeration control components, such operating principles and



Mimic Diagram

Note: Specifications are subject to change.

Tesca Technologies Pvt. Ltd.

IT-2013, Ramchandrapura Industrial Area, Sitapura Extension,
Near Bombay Hospital, Vidhani Circle, Jaipur-302022, Rajasthan, India,
Tel: +91-141-2771791 / 2771792; Email: info@tesca.in, tesca.technologies@gmail.com
Website: www.tescaglobal.com

- common fault & trouble shooting method
- Learn the sizing of condenser, evaporator and compressor units
- Troubleshooting of refrigeration cycle failure symptom and caused
- Basic electric control circuit and system of common air conditioning system
- System Setup: initial leak detection, leak detection, evacuating a refrigerant
- Study on receiver liquid receiver and suction line accumulator
- Familiarization with various types of compressor
- Investigation on the operation of the compressor

- Voltage : 240
- Condenser
 - Forced air coil with variable speed fan
- Control devices
 - Capillary tube
 - Thermometer
 - Solenoid valves
 - Thermostatic controller
 - Flow Meter
 - Wattmeter, Voltmeter, Ammeter
- Safety features
 - Safety pressure switch
 - Main breaker switch
 - Compressor breaker switch
- Evaporator
 - Air Cooled Type
 - Water Source Type

Technical Specifications

- Compressor
 - Hermetic : 450 Watt
 - Refrigerant : R-134A

Legend (n).	Descriptions'	Function
1	Power switch	Main power switch to refrigeration trainer
2	Start & stop button	To control the compressor run or stop.
3	Condenser fan speed control switch	To control condenser fan's run or stop.
4	Digital power meter	To display the compressor's power consumption, including A, V, PF, watt & Kvar.
5	Air source evaporator	Evaporator's finned tube heat exchanger with induced draft fan.
6	Temperature indicator	To indicates the temperature reading at different point. In unit of Celsius.
7	Flow meter indicator	To indicate the water flow rate enter to the evaporator tank, in liter/minutes unit.
8	Pressure gauge	Refrigeration low side pressure reading.
9	Pressure gauge	Refrigeration high side pressure reading.
10	Thermostatic expansion valve	Automatic expansion valve and refrigerant flow rate correction control caused refrigerant expansion effects.
11	Capillary tube	To reduce the high side pressure and caused refrigerant expansion effects.
12	Manual ON/OFF ball valve	To open or shut off the flow line, also can be throttle the flow rate by partial open of the valve, in order to achieved refrigerant expansion.
13	Side glass	Refrigerant side glass for viewing the status of refrigerant (i.e. liquid, vapor, vapor –liquid states).
14	Pressure gauge	Compressor suction side pressure reading.
15	Reversing valve	To change the operation mode from refrigeration (cool) to heat pump (heat) or vice-versa. When the handle is in horizontal position indicates refrigeration mode. While the handle in vertical down position indicates heat pump mode. User should shut down the compressor, before changing the operation mode.
16	Compressor	Hermetic compressor of 1hp, 240Vac, 50Hz. R134a refrigerant used.
17	Pressure gauge	Compressor discharge side pressure reading.
18	Condenser	Air cool condenser
19	Water source evaporator	This evaporator made of transparent Perspex pipe with two flanges at the top and bottom; they fasten by four tie rod shaft, to achieved complete leak proof of water. Internal of the evaporator

Note: Specifications are subject to change.

Tesca Technologies Pvt. Ltd.

IT-2013, Ramchandrapura Industrial Area, Sitapura Extension,
Near Bombay Hospital, Vidhani Circle, Jaipur-302022, Rajasthan, India,
Tel: +91-141-2771791 / 2771792; Email: info@tesca.in, tesca.technologies@gmail.com
Website: www.tescaglobal.com

		consist 1/4" copper spiral coil with Refrigerant is passed through in. This spiral coil is act as heat exchanger for this evaporator. The evaporator consists of; 1. Two water connection port, i.e. inlet and outlet. 2. Two refrigerant connection port, i.e. inlet and outlet.
20	Manual ball valve (water outlet control valve)	Manual ball valve for open and shut off of the fluid line.
21	Manual ball valve (water inlet control valve)	Manual ball valve for open and shut off of the fluid line.
22	Flow sensor	Vane type, pulse output (NPN) flow sensor. The pulse signal is connected to flow indicator at the mimic diagram. (Detail specification please refers to technical manual enclosed.)
23	Refrigerant flow meter	Variable area type flow meter to indicate the refrigerant flow rate in liter/minute.
24	Filter	Refrigerant filter unit

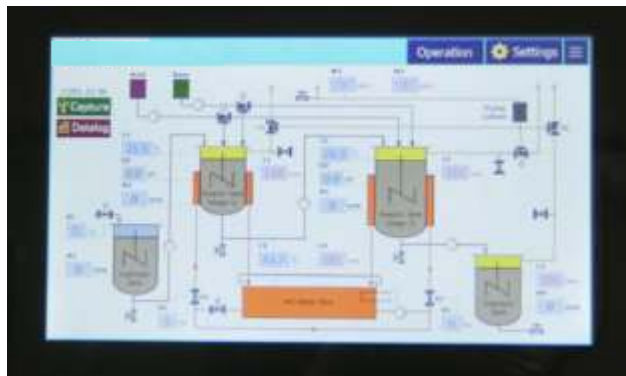

Touch Screen Panel

Option: Computer Controller System:

Designed For Computer Control Plus Data Acquisition. Touch Screen Panel

- 13" Touch Screen Panel integrated into trainer
- Integrated processor computer
- HDMI output
- Board with data acquisition and control.
- Individual board for each sensor for signal processing.
- Power supply included.
- Different type of connectors for each sensor for avoiding connections mistakes between unit and interface.
- Single cable for connecting interface and computer, for avoiding dangerous and mistakes.

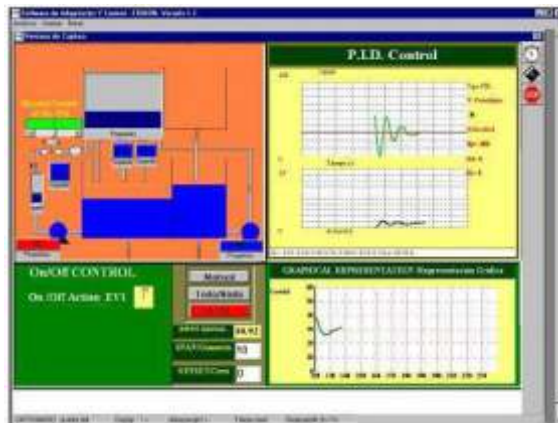

Screen Shot

Scope of Delivery

Operating instructions, Student experiment book, Teacher's answer book.

Note: Specifications are subject to change.

Tesca Technologies Pvt. Ltd.

IT-2013, Ramchandrapura Industrial Area, Sitapura Extension,
Near Bombay Hospital, Vidhani Circle, Jaipur-302022, Rajasthan, India,
Tel: +91-141-2771791 / 2771792; Email: info@tesca.in, tesca.technologies@gmail.com
Website: www.tescaglobal.com

