



LFC™ _5E Range Of Surge Reduction Check Valve

Overview:

The LFC™ _5E Range Of Surge Reduction Check Valve stops reverse flow. It is commonly used in pump stations to stop the pump from running in reverse when the pump is stopped. LFC™ _5E Range Of Surge Reduction Check Valves were designed to reduce the effects of water hammer when the check valve shuts down. Most conventional check valves on the market today only reduce flow in the last 30% of closure resulting in a rapid slamming action which creates water hammer.

The LFC™ _5E Range Of Surge Reduction Check Valves were developed to be more energy efficient with a better flow co-efficient (Cv) than most nozzle check valves on the market today. The nozzle check valve reduces the effects of water hammer but none of our competitors are energy efficient. In pumping systems, energy efficiency is crucial. Energy efficient valves will allow for a maximum amount of fluid to be pumped in the shortest amount of time that the pumping system can deliver. Whereas the time to pump the same amount of fluid with low energy efficiency valves will increase. Over time this will drastically increase the running cost of the pump station due to increased energy requirements as well as wear and tear on pumps and valves.

The LFC™ _5E Range Of Surge Reduction Check Valve has been developed to present a robust, simple and cost effective high pressure (up to 25 MPa / 3 626 Psi) solution to fluid handling issues in any industrial sector.

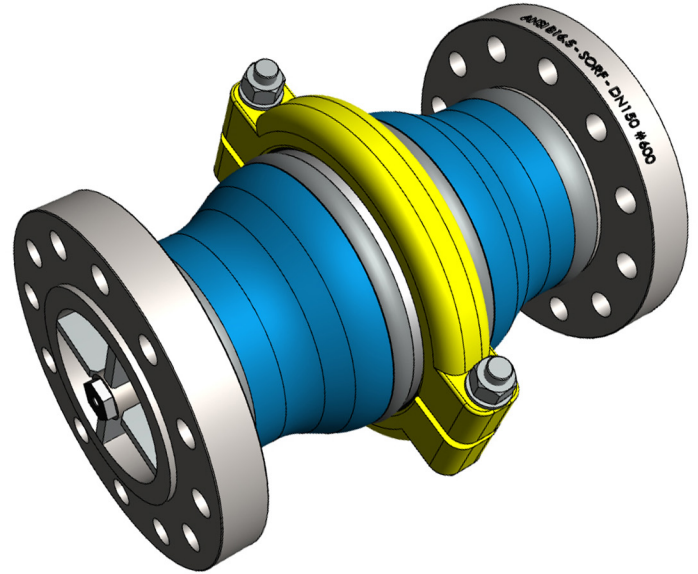

Operating Conditions:

These valves are designed to operate in systems with relatively clean media like water or other liquids with a low percentage of suspended solids and chlorides. The valve's operating pH range is 2 – 14 pH.

Simplicity:

The LFC™ _5E Range Of Surge Reduction Check Valve, disc is shaped to allow for a smoother flow path around it. The disc is carried by a shaft that can slide in two guides on the inlet and outlet side of the LFC™ _5E Range Of Surge Reduction Check Valve body. On the outlet side of the Surge Reduction Check Valve body guide, the guide is partly closed creating a compartment. By closing the compartment partly, during a closing operation a vacuum is created inside the compartment of the guide. This prevents the disc from slamming shut and the LFC™ _5E Range Of Surge Reduction Check Valve therefore closes in a controlled manner which drastically reduces the occurrence of water hammer.

By carrying the disc on a shaft, bushes and guides, we increase the life of the LFC™ _5E Range Of Surge Reduction Check Valve when compared to conventional check valves. Conventional check valves all have a hinge systems attached to the door / disc. These hinge systems are not very reliable as the hinges wear out and prevent the door /disc from closing to the correct position causing the check valve to leak and fail.

A spring is installed in the LFC™ _5E Range Of Surge Reduction Check Valve to keep it in the closed position for commissioning. After the system is charged with pressure, the pressure acts on the moving wetted parts and forces the LFC™ _5E Range Of Surge Reduction Check Valve closed and the spring serves no purpose. Once the pump starts or the pressure is higher from the inlet side of the LFC™ _5E Range Of Surge Reduction Check Valve, the higher pressure pushes the check valve disk open.

Low Maintenance Requirement:

LFC™ _5E Range Of Surge Reduction Check Valve only has one moving part making it very reliable. It is manufactured from stainless steel which increases reliability and durability. LFC™ _5E Range Of Surge Reduction Check Valve requires minimal maintenance which is made easy by its split body configuration.

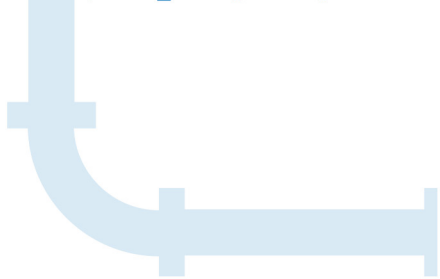



LFC™_5E Range Of Surge Reduction Check Valve

The Effects Of Water Hammer:

See the effects of water hammer on an underground pump station with 770m static head in an Mine when 1 pump was tripped using a conventional double door check valve.

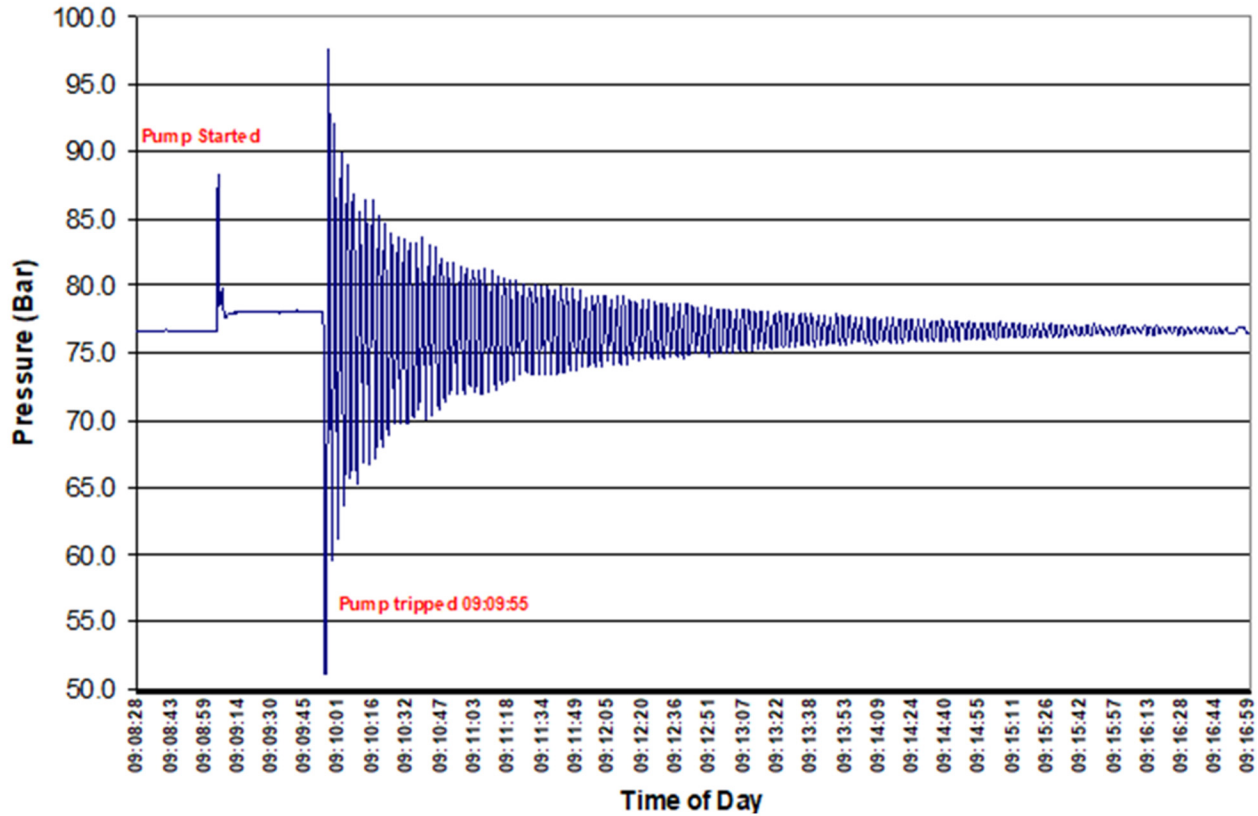

The Effects Of Using A LFC™_5E Range Of Surge Reduction Check Valve:

See the effects of how installing the LFC™_5E Range Of Surge Reduction Check Valve drastically reduced the severity of the water hammer at the underground pump station in a Mine with a static head of 1192m when 1 pump was tripped.

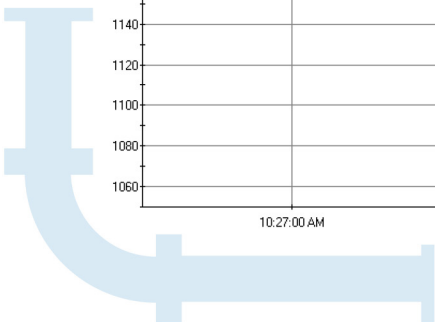
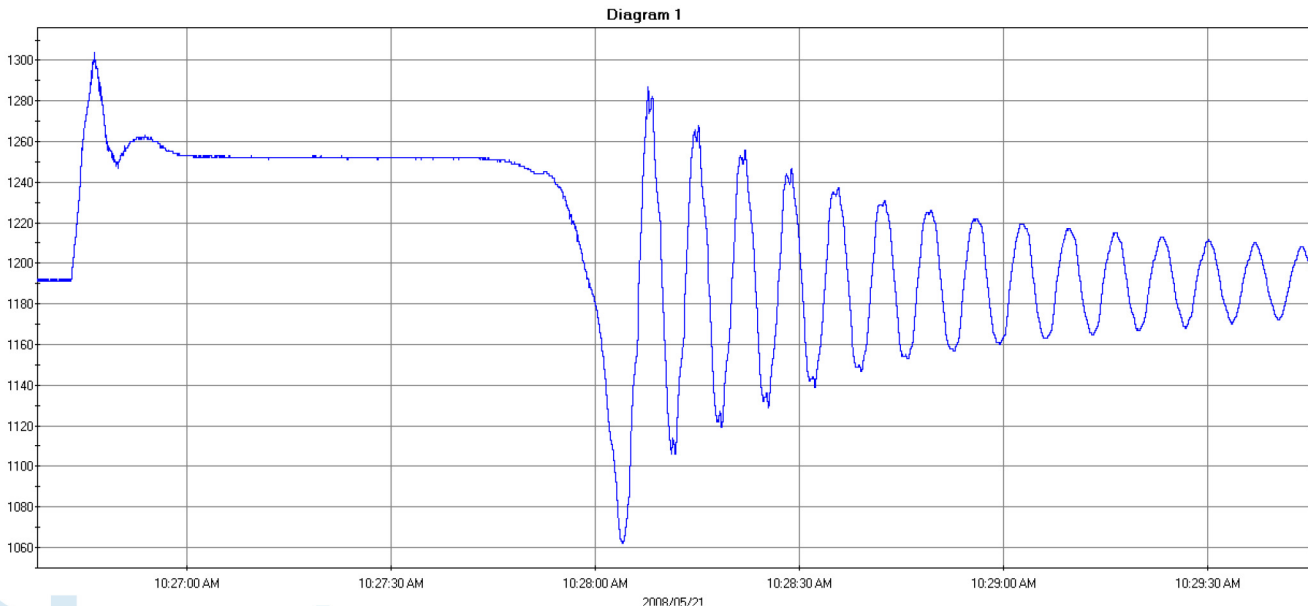



LFC™_5E Range Of Surge Reduction Check Valve

Materials Of Construction & Dimensions:

Part Name	Specification	Face to face dimensions						
		Unit	#600		#900		#1500	
			(mm)	(inch)	(mm)	(inch)	(mm)	(inch)
Intel body	Casting - BS3100 Gr. A2	DN100 / 4"	431	16.97	457	17.99	546	21.50
Inlet body seat #1	309 S/Steel	DN150 / 6"	559	22.01	610	24.02	705	27.76
Inlet body seat #2	F6	DN200 / 8"	660	25.98	737	29.02	832	32.76
Inlet body seat #3	F12	DN250 / 10"	787	30.98	838	32.99	991	39.02
Outlet body	Casting - BS3100 Gr. A2	DN300 / 12"	838	32.99	965	37.99	1130	44.49
Flanges	ASTM A105	DN350 / 14"	889	35.00	1029	40.51	1257	49.49
Disc	431 S/Steel	DN400 / 16"	991	39.02	1130	44.49	1384	54.49
Shaft	431 S/Steel							
Shaft bush	LG 2							
Guide bush	431 S/Steel							
O-Rings	Nitrile (Buna)							
Clamps	BS3100 Gr. A2							

Flow Rates:

Flow (ℓ/sec)	25	35	50	100	150	200	250	300	350	400
Pressure drop (kPa)	DN100	7	12							
	DN150	4	5	8	27					
	DN200			4	8	16	34			
	DN250				2	5	10	15	24	
	DN300					4	9	13	17	22
Flow US gallon / min	396.26	554.76	792.52	1585.03	2377.55	3170.06	3962.58	4755.09	5547.61	6340.12
Pressure drop (psi)	4"	1.02	1.74							
	6"	0.58	0.73	1.16	3.92					
	8"			0.58	1.16	2.32	4.93			
	10"				0.29	0.73	1.45	2.18	3.48	
	12"					0.58	1.31	1.89	2.47	3.19

Design & Manufacturing Standards:

LFC™_5E Range Of Surge Reduction Check Valve has been designed in accordance with various international standards as set out below:

ASME Boilers and pressure vessels design code

ANSI B16.10 ANSI B16.3

ANSI B16.34 ANSI B16.37

ANSI B16.5 ANSI N278.1

Available sizes: DN50 / 2" to DN600 / 18"

Pressure rating: up to 25MPa / 3 626 psi

Face to face dimensions: ANSI B16.10 or other, minimum #600

Available end connections: ANSI B16.5, BS4504, BS10, AS/NZS 4331.1 (ISO 7005-1) DIN, all makes of grooved or ring joint couplings, and other as per clients requirement.

