



TAPARIA TOOLS LTD.

AN ISO-9001 COMPANY



ADJUSTABLE SPANNERS



- ★ Forged with high grade Steel, and heat treated to give long trouble free service.
- ★ Left hand thumb screw movement as standard. Right hand thumb screw movement available on request.
- ★ Precision marked scale indicate correct jaw opening.
- ★ Available in Bright polished Nickel Chrome finish and Black Phosphate finish.
- ★ Also available with soft grip to provide comfortable gripping in use.

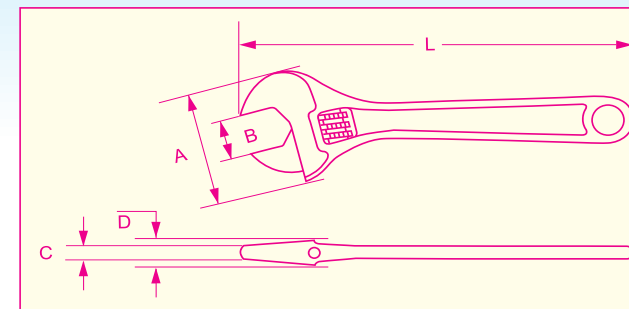

PROD. NO	A	B	C	D	L	WT. GMS	
						WITHOUT GRIP	WITH GRIP
1169	33	13	4	8.20	110	50	55
1170	46	19	6	11.20	155	125	145
1171	59	26	7	13.65	205	230	260
1172	70	30	9	16.55	255	390	430
1173	79	35	10	18.40	305	590	635
1174	97	43	12.5	21.00	380	960	1025
1175	120	57	14.0	25.00	450	1880	-
1176	138	64	15.0	28.00	608	2980	-
1177	180	90	19.0	34.0	780	5920	-

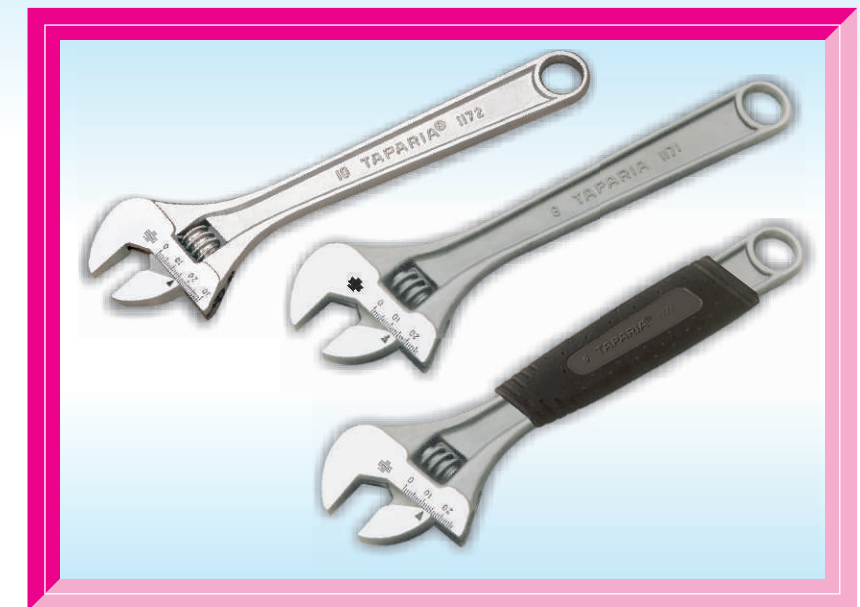

BLISTER PACKING

DISPLAY PACKING

HANGING CARD

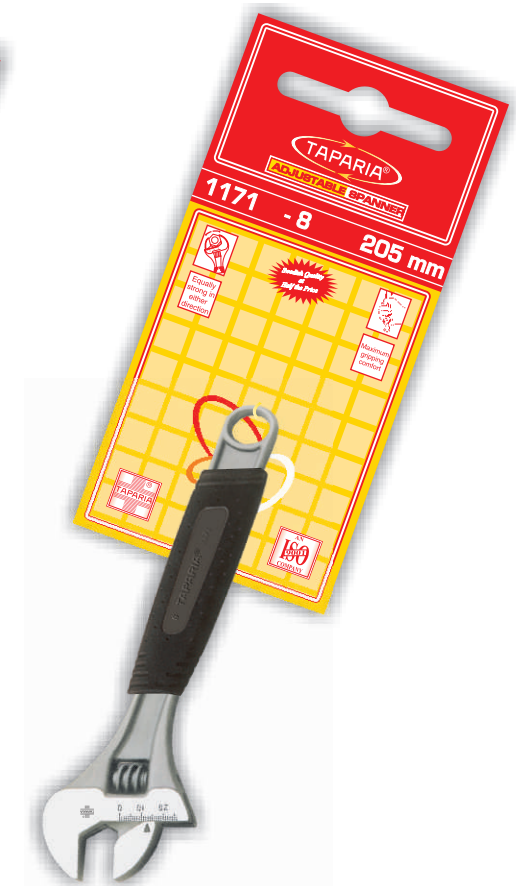
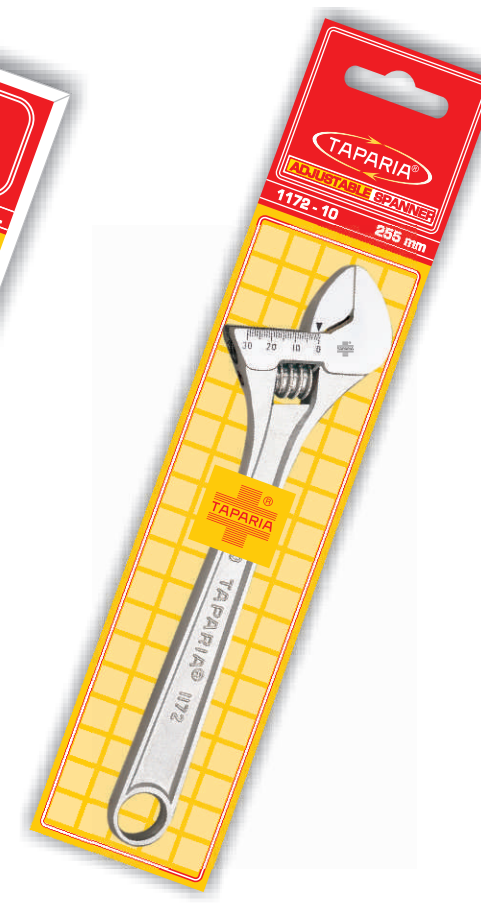
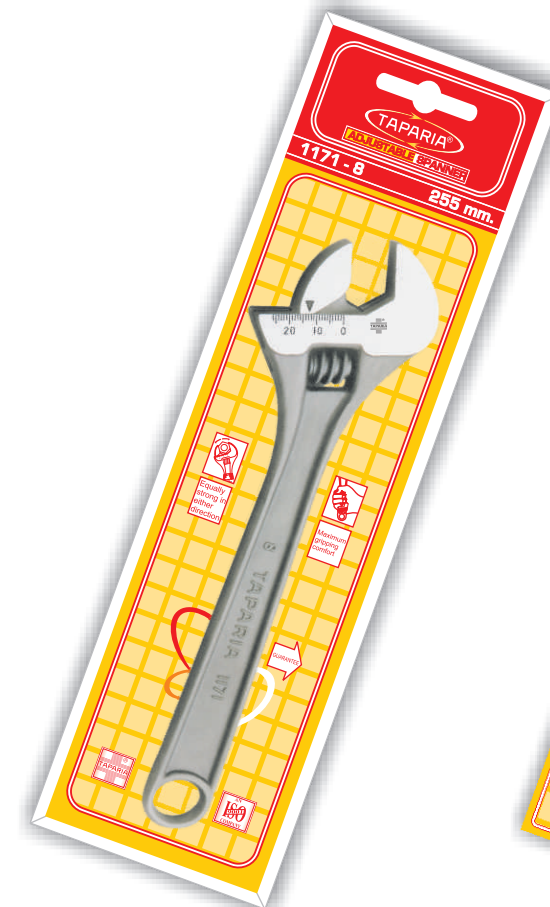

TAPARIA TOOLS LTD.



Head Office : 423 / 424, A-2, Shah & Nahar, Lower Parel (W), Mumbai - 400 013. & : 61478600
 Fax : 91-22-2495 3230. • E-mail : sales@tapariatools.com • Web Site : http://www.tapariatools.com
 Works : 52-B, M. I. D. C., Satpur, Nashik - 422 007. & : 2350 317 / 318 / 418 • Fax : 0253-2350740



An ISO-9001 Company

TAPARIA® TAPARIA® TAPARIA® TAPARIA® TAPARIA®



TAPARIA TOOLS LTD.

AN ISO-9001 COMPANY



ALLEN KEYS

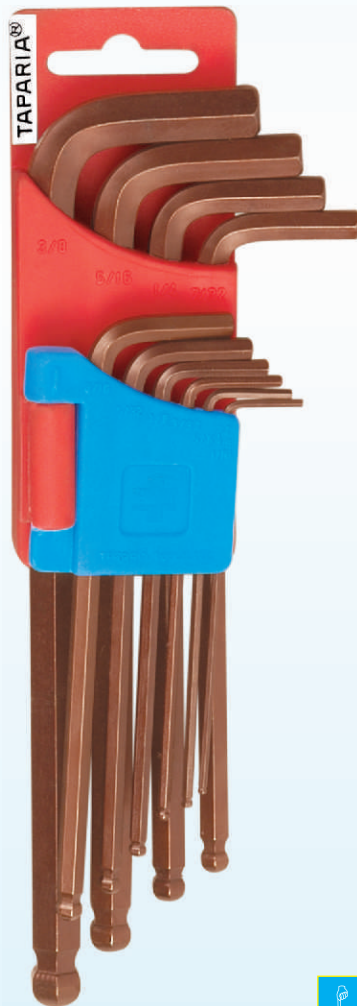

- ☛ Made from high grade alloy steel.
- ☛ Accurately hardened and tempered to withstand higher torque and enable high wear resistance.
- ☛ Available in brown & black finish.
- ☛ Offered in loose as well as in sets.
- ☛ One of the widest range of Allen Keys in India.

ALLEN KEYS BROWN FINISH

- Made from expensive high-grade alloy steel.
- Accurately hardened and tempered to 58-62 HRC to withstand higher torque and enable high wear resistance.
- Taparia Brown Finish Allen Keys look aesthetically rich.
- Taparia Metric series Allen Keys are made as per IS 3082 & Din 911 standard and Inch series Allen Keys are made as per BS 2470 standard
- Offered in loose as well as in Sets.

Allen Keys Brown Finish (mm. Series)

PROD. NO.	L 1	L 2	WT. GMS.
AK-1.5	45	14	1
AK-2	50	16	2
AK-2.5	56	18	3
AK-3	63	20	5
AK-4	70	25	12
AK-5	80	28	20
AK-6	90	32	30
AK-8	100	36	60
AK-10	112	40	105

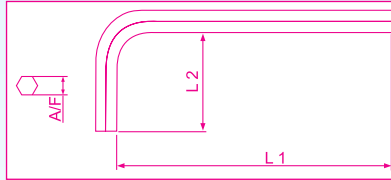

Allen Keys Brown Finish (Inch Series)

PROD. NO.	L 1	L 2	WT. GMS.
AK-1/16	44	14	1
AK-5/64	48	15	2
AK-3/32	51	17	3
AK-1/8	57	19	5
AK-5/32	64	21	9
AK-3/16	70	24	14
AK-7/32	75	26	23
AK-1/4	83	28	28
AK-5/16	95	32	57
AK-3/8	108	35	92

Allen Keys Set Brown Finish (Inch Series)

PROD. NO.	SIZE
AKI - 10 (Box packing)	10 Pcs. Set (1/16", 5/64", 3/32", 1/8", 5/32", 3/16", 7/32", 1/4", 5/16" & 3/8")
AKHI - 10 (Hanger packing)	10 Pcs. Set (1/16", 5/64", 3/32", 1/8", 5/32", 3/16", 7/32", 1/4", 5/16" & 3/8")

Allen Keys Set Brown Finish (mm. Series)

PROD. NO.	SIZE
AKM - 9 (Box packing)	9 Pcs. Set (1.5mm, 2mm., 2.5mm., 3mm., 4mm., 5mm., 6mm., 8mm., 10mm)
AKHM - 9 (Hanger packing)	9 Pcs. Set (1.5mm, 2mm., 2.5mm., 3mm., 4mm., 5mm., 6mm., 8mm., 10mm)

ALLEN KEYS BLACK FINISH

- Taparia Black finish Allen Keys are made from CrV Steel
- They are accurately hardened and tempered to 52-56 HRC to withstand high torque and have high wear resistance.
- Taparia Metric series Allen Keys are made as per IS 3082 & Din 911 standard and Inch series Allen Keys are made as per BS 2470 standard
- Taparia Allen Keys are offered in loose as well as in Sets.

Allen Keys Black Finish (mm. Series)

PROD. NO.	SIZE	L1	L2
K1.5V	1.5 mm.	44	14
K2V	2 mm.	48	15
K2.5V	2.5 mm.	51	17
K3V	3 mm.	57	19
K4V	4 mm.	64	21
K5V	5 mm.	71	24
K6V	6 mm.	84	28
K8V	8 mm.	96	32
K10V	10 mm.	108	35
AK-12	12 mm	125	45
AK-14	14 mm	140	56
AK-17	17 mm	160	63
AK-19	19 mm	180	70
AK-22	22 mm	200	80
AK-24	24 mm	224	90
AK-27	27 mm	250	100
AK-30	30 mm	280	112
AK-32	32 mm	315	125
AK-36	36 mm	355	140

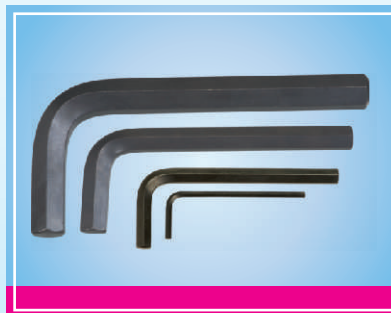
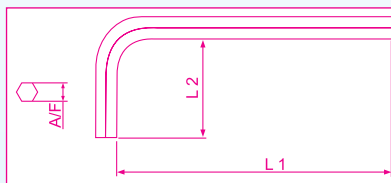

Allen Keys Black Finish (Inch Series)

PROD. NO.	L 1	L 2	WT. GMS.
K1/16	44	14	1
K5/64	48	15	2
K3/32	51	17	3
K1/8	57	19	5
K5/32	64	21	9
K3/16	70	24	14
K7/32	75	26	23
K1/4	83	28	28
K5/16	95	32	57
K3/8	108	35	92
AK-1/2	125	45	185
AK-9/16	140	56	275
AK-5/8	160	63	385
AK-3/4	180	70	625
AK-7/8	200	80	960
AK-1	235	90	1575

Allen Key Set Black Finish (mm. Series)

PROD. NO.	SIZE
KM - 9 V (Box packing)	9 Pcs. Set (1.5mm., 2mm., 2.5mm., 3mm., 4mm., 5mm., 6mm., 8mm., 10mm)
KHM - 9 V (Hanger packing)	

Allen Key Set Black Finish (Inch. Series)

PROD. NO.	SIZE
KI - 10 V (Box packing)	10 Pcs. Set (1/16", 5/64", 3/32"
KHI - 10 V (Hanger packing)	1/8", 5/32", 3/16", 7/32", 1/4", 5/16" & 3/8"



Allen Keys Long Ball Point (mm. Series)

PROD. NO.	SIZE	L1	L2	WT. GMS.
KB 1.5 L	1.5 mm.	77	13	2
KB 2 L	2 mm.	82	15	3
KB 2.5 L	2.5 mm.	88	17	5
KB 3 L	3 mm.	98	19	7
KB 4 L	4 mm.	104	24	15
KB 5 L	5 mm.	116	27	25
KB 6 L	6 mm.	138	31	40
KB 8 L	8 mm.	157	35	80
KB 10 L	10 mm.	167	39	140

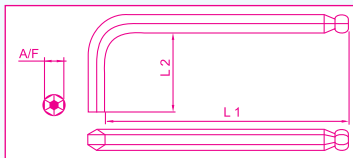

Allen Keys Long Ball Point (Inch Series)

PROD. NO.	SIZE	L1	L2	WT. GMS.
KB 1/16 L	1/16	77	13	2
KB 5/64 L	5/64	82	15	3
KB 3/32 L	3/32	88	17	5
KB 1/8 L	1/8	98	19	7
KB 5/32 L	5/32	104	24	14
KB 3/16 L	3/16	116	27	23
KB 7/32 L	7/32			36
KB 1/4 L	1/4	138	31	46
KB 5/16 L	5/16	157	35	78
KB 3/8 L	3/8	167	39	134

Allen Keys Extra Long Ball Point (mm. Series)

PROD. NO.	SIZE	L1	L2	WT. GMS.
KB1.5X	1.5 mm.	90	14	2
KB2X	2.0 mm.	100	16	4
KB2.5X	2.5 mm.	112	18	6
KB3X	3.0 mm.	128	20	10
KB4X	4.0 mm.	140	25	15
KB5X	5.0 mm.	160	28	30
KB6X	6.0 mm.	180	32	45
KB8X	8.0 mm.	200	36	100
KB10X	10.0 mm.	224	40	175



Allen Keys Extra Long Ball Point (Inch Series)

PROD. NO.	SIZE	L1	L2	WT. GMS.
KB1/16X	1/16	90	4	2
KB5/64X	5/64	100	6	4
KB3/32X	3/32	112	8	6
KB1/8X	1/8	128	20	10
KB5/32X	5/32	140	25	15
KB3/16X	3/16	160	28	25
KB7/32X	7/32	170	30	40
KB1/4X	1/4	180	32	55
KB5/16X	5/16	200	36	100
KB3/8X	3/8	224	40	160

Long Ball Point Keys Set (mm. Series)

PROD. NO.	9 Pcs. Hanger Packing Set
	SIZE
KBHM 9 L	(1.5mm, 2mm., 2.5mm., 3mm., 4mm., 5mm., 6mm., 8mm., 10mm)

Extra Long Ball Point Keys Set (mm Series)

PROD. NO.	9 Pcs. Hanger Packing Set
	SIZE
KBHM 9 X	(1.5mm, 2mm., 2.5mm., 3mm., 4mm., 5mm., 6mm., 8mm., 10mm)



Long Ball Point Keys Set (Inch. Series)

PROD. NO.	10 Pcs. Hanger Packing Set
	SIZE
KBHI 10 L	(1/16", 5/64", 3/32", 1/8", 5/32", 3/16", 7/32", 1/4", 5/16" & 3/8"

Extra Long Ball Point Keys Set (Inch Series)

PROD. NO.	10 Pcs. Hanger Packing Set
	SIZE
KBHI 10 X	(1/16", 5/64", 3/32", 1/8", 5/32", 3/16", 7/32", 1/4", 5/16" & 3/8"

TORX KEYS

- Taparia Torx Keys are made from high grade alloy steel.
- They are accurately hardened and tempered to 55-60 HRC to withstand high torque and have high wear resistance.
- Taparia offers a wide range of Torx keys from T-5 to T-50 sizes
- Taparia Torx Keys are offered in loose and in sets.

TORX KEYS (Short Series)

PROD. NO.	SIZE	ØF	L1	L2	WT. GMS
KT 5 S	T 5	3.0	42	16	3
KT 6 S	T 6	3.0	42	16	3
KT 7 S	T 7	3.0	48	16	4
KT 8 S	T 8	3.0	48	16	4
KT 9 S	T 9	3.0	48	16	4
KT 10 S	T 10	3.0	51	18	4
KT 15 S	T 15	3.5	54	18	5
KT 20 S	T 20	4.0	57	20	8
KT 25 S	T 25	4.5	60	21	10
KT 27 S	T 27	5.0	64	22	13
KT 30 S	T 30	6.0	70	25	20
KT 40 S	T 40	7.0	76	27	30
KT 45 S	T 45	8.0	82	29	35
KT 50 S	T 50	9.0	95	33	60



TORX KEYS SETS (Short Series)

PROD. NO.	SIZE
KTH 7 S	T10, T15, T20, T25, T27, T30, T40
KTH 8 S	T5, T6, T7, T8, T9, T10, T15, T20
KTH 9 S	T10, T15, T 20, T25, T27, T30, T40 T45, T50

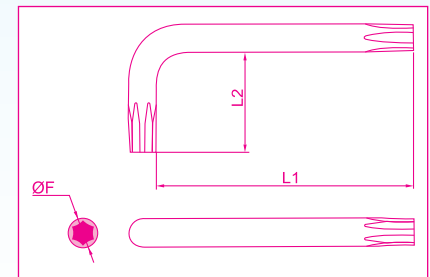

FOLDING KEY SETS (BELISTER PKG.)



PROD. NO.	SIZE
KFM 8	Hex Allen Keys (1.5mm., 2mm., 2.5mm., 3mm., 4mm., 5mm., 6mm., 8mm.)
KFI 9	Hex Allen Keys (5/64, 3/32, 7/64, 1/8, 9/64, 5/32, 3/16, 7/32, 1/4)
KFT 8	Torx Keys (T9, T10, T15, T20, T25, T27, T30, T40)



TAPARIA TOOLS LTD.



Head Office : 423 / 424, A-2, Shah & Nahar, Lower Parel (W), Mumbai - 400 013. & : 2493 8646 - 50
Fax : 91-22-2495 3230. • **E-mail :** sales@tapariatools.com • **Web Site :** http://www.tapariatools.com
Works : 52-B, M. I. D. C., Satpur, Nashik - 422 007. & : 2350 317 / 318 / 448 **Fax :** 0253-2350740



An ISO-9001 Company

TAPARIA® TAPARIA® TAPARIA® TAPARIA® TAPARIA®



TAPARIA TOOLS LTD.

AN ISO-9001 COMPANY



CANTILEVER TOOL BOXES

CANTILEVER TOOL BOXES

- ★ For storing different types of tools, accessories etc.
- ★ Made from high gauge steel sheet for higher strength and long life.
- ★ Two steel handles for balanced and comfortable carrying.
- ★ Assembled with stainless steel rivets for extra strength and rust prevention.
- ★ Superior Powder coated for rust protection.
- ★ Provision for locking.
- ★ Boxes are available in 3 and 5 compartments.



5 Compartments



3 Compartments

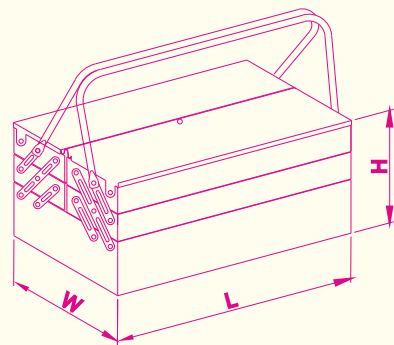

PRODUCT NO.	Dimensions in mm			Weight Carrying Capacity
	H	W	L	
CTB 1805	205	200	450	15 kgs. Max.
CTB 1803	155	200	450	10 kgs. Max.

BOX SPANNERS

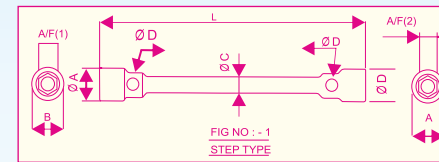

L TYPE SPANNERS

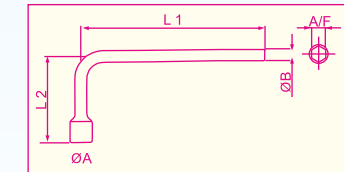

PROD. NO	FIG.NO	ØA	ØB	ØC	ØD	A/F(1)	A/F(2)	L	WT. KGS.
HD 1720	2	49	45	25	21.4	30	32	400	2.00
HD 1725	3	42	42	25	21.4	27	30	400	1.92
1728	1	42	38	23	21.4	24	27	400	1.53
HD 1730	2	49	42	25	21.4	27	33	400	1.90
1731	1	42	42	23	21.4	27	27	400	1.44
HD 3030	3	45	45	25	21.4	30	30	400	2.00
1740	1	50	50	23	21.4	32	32	400	1.80
CHD 1740	1	49	49	25	21.4	32	32	400	1.88
HD 3233	1	49	49	25	21.4	32	33	400	1.93
1741	1	50	50	23	21.4	33	33	400	1.58
HD 1741	1	49	46	25	21.4	33	33	400	1.94

PROD. NO	ØD	ØD	L	L	WT. GMS	
T1535	28	16	250	115	18	600
1536 S	30	16	250	115	19	610
1536	30	16	300	140	19	715
1537	32	16	310	140	21	755

Generally conforming to IS 2030-1989

PRODUCT NO. AND SIZE	S1	S2	ØD	L	WEIGHT GRAMS.
TS 6 X 7	6.0	7.0	9.2	115	35
TS 8 X 9	8.0	9.0	12.8	120	45
TS 10 X 11	10.0	11.0	12.8	125	65
TS 12 X 13	12.0	13.0	15.7	135	95
TS 14 X 15	14.0	15.0	15.7	140	120
TS 16 X 17	16.0	17.0	19.0	150	145
TS 18 X 19	18.0	19.0	22.0	160	160
TS 18 X 19	18.0	19.0	22.0	160	160
TS 20 X 22	20.0	22.0	25.0	170	225
TS 21 X 23	21.0	23.0	25.0	175	235
TS 24 X 27	24.0	27.0	28.5	185	285
TS 25 X 28	25.0	28.0	31.0	190	335
TS 30 X 32	30.0	32.0	35.0	205	480

(8 pcs.) with Tommy Bar :

Prod. No.	Contents
TS 08 (8 Pcs Set)	6x7, 8x9, 10x11, 12x13, 14x15, 16x17, 18x19, 20x22 Tommy Bar : 1) Dia 12 x 250 mm. 2) Special Tommy Bar
TS 12 (12 Pcs Set)	6x7, 8x9, 10x11, 12x13, 14x15, 16x17, 18x19, 20x22, 21x23, 24x27, 25x28, 30x32 Tommy Bar : 1) Dia 12 x 250 mm. 2) Special Tommy Bar

TUBULAR BOX SPANNERS



TUBULAR SPANNERS SET



TAPARIA TOOLS LTD.

Head Office : 423 / 424, A-2, Shah & Nahar, Lower Parel (W), Mumbai - 400 013. & : 6147 8600
 Fax : 91-22-2495 3230. • E-mail : sales@tapariatools.com • Web Site : http://www.tapariatools.com
 Works : 52-B, M. I. D. C., Satpur, Nashik - 422 007. & : 2350 317 / 318 / 418 CIN : L99999MH1965PLC013392



AN ISO-9001 - 2015 COMPANY

TAPARIA® TAPARIA® TAPARIA® TAPARIA® TAPARIA®



TAPARIA TOOLS LTD.

AN ISO-9001 COMPANY



CHISELS



- Made from high grade Steel, forged and ground.
- Differential heat treatment for cutting edge, and striking end, ensures long life.
- Bright Blue Painted finish.

OCTAGONAL CHISEL

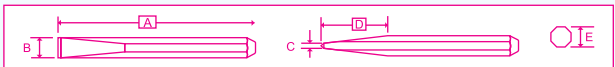

PROD. NO	A	B	C	D	E	WT. GMS
101	135	9	1.50	40	9 A/F	58
102	150	16	3.25	70	12 A/F	134
104	200	22	3.75	90	15 A/F	272
105	200	25	4.00	100	19 A/F	365
106	250	30	4.50	120	22 A/F	710
107	300	32	4.75	130	22 A/F	904

FLAT CHISEL

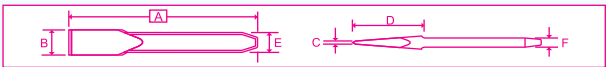

PROD. NO	A	B	C	D	E	F	WT. GMS
1046	150	20	3.0	57	17	10.00	171
1048	200	25	3.5	83	20	10.00	258
1059	235	24	2.5	90	24	6.35	268

PNEUMATIC CHISEL

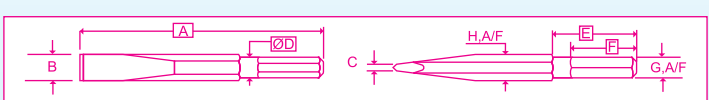

PROD. NO	A	B	C	Ø D	E	F	G, A/F	H, A/F	WT. GMS
1306	150	22	3.0	17.25	65	46.5	14.8	19	254
1307	175	22	3.0	17.25	65	46.5	14.8	19	302
1308	200	22	3.0	17.25	65	46.5	14.8	19	320
1309	225	22	3.0	17.25	65	46.5	14.8	19	430

FLAT OCTAGONAL CHISEL (RUBBER GRIP)

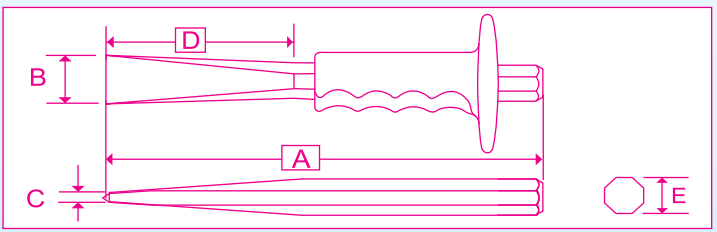

PROD. NO	A	B	C	D	E	F	WT. GMS
106 R	250	30	4.5	120	22	-	820
1059 R	235	24	2.5	90	24	6.35	350



TAPARIA TOOLS LTD.

AN ISO-9001 COMPANY



C-CLAMP

- ★ Body Hot drop forged from high grade steel.
- ★ All parts fully heat treated and Black Phosphated for long trouble free service.
- ★ Ideal for heavy duty application.

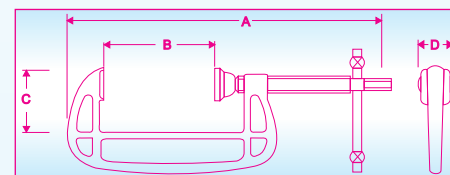
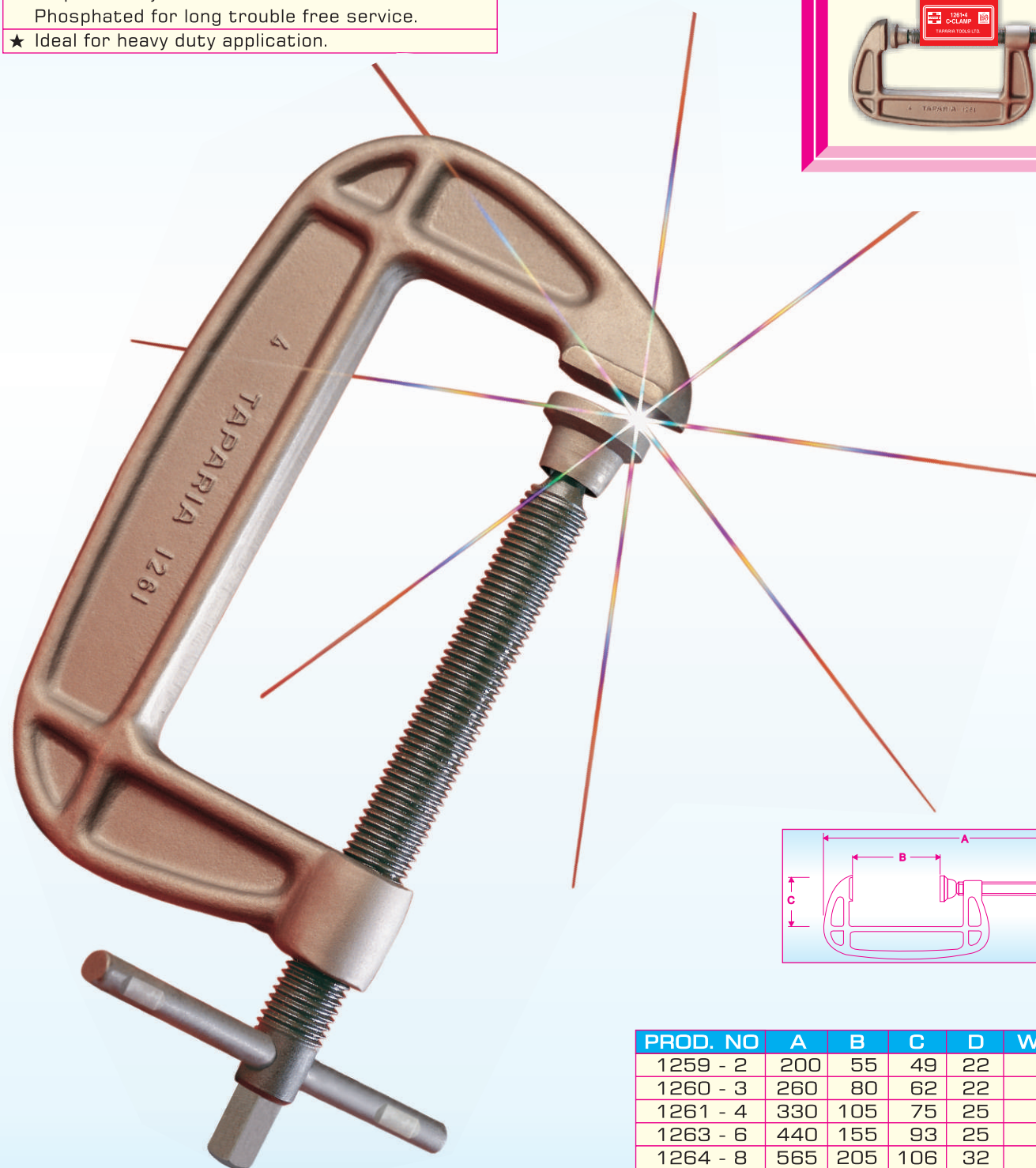
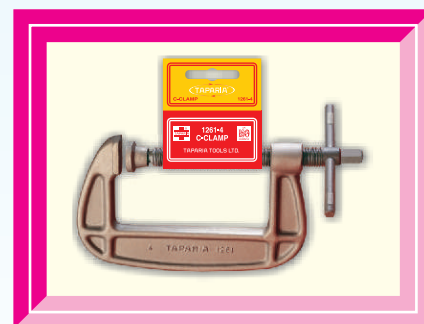

PROD. NO	A	B	C	D	WT. GMS
1259 - 2	200	55	49	22	360
1260 - 3	260	80	62	22	570
1261 - 4	330	105	75	25	1060
1263 - 6	440	155	93	25	1700
1264 - 8	565	205	106	32	2840

F CLAMPS

- ★ Forged from superior grade steel, high quality, durable, clamping tool, which retains its dimensions and resists distortion even at high clamping force.
- ★ Available in Light Duty and Heavy duty variety.
- ★ Light Duty is good for carpentry and Heavy duty I good for holding steels and in fabrication.
- ★ Fixed bracket and pressure plate are produced from a single piece which gives maximum strength.
- ★ Swivelling type pressure plate can be fitted on uneven, angled or sloping surfaces.
- ★ Sturdy Tommy bar has special rounded ends which gives comfortable gripping.

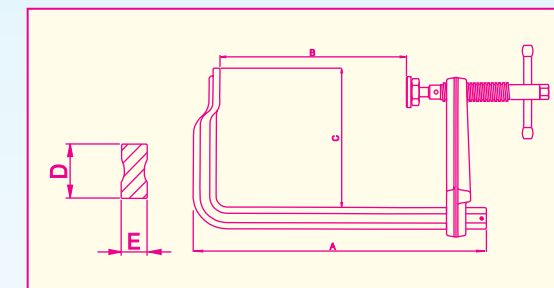

Light Duty F Clamp

Product No.	A	B	C	D	E	Weight Grams
FC15200	270	200	80	15.5	7.5	540
FC15250	320	250	80	15.5	7.5	580
FC22300	390	300	120	22	10.6	1360
FC22400	490	400	120	22	10.6	1530
FC22500	590	500	120	22	10.6	1700
FC22600	690	600	120	22	10.6	1900

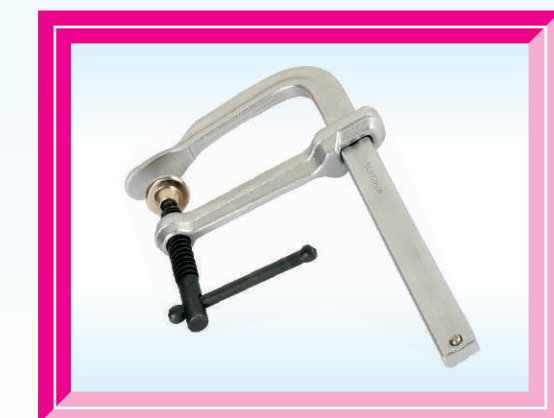

Heavy Duty F Clamp

Product No.	A	B	C	D	E	Weight Grams
FC29250	380	250	120	29.7	14.3	2700
FC29300	430	300	120	29.7	14.3	2880
FC29400	530	400	120	29.7	14.3	3180
FC29500	630	500	120	29.7	14.3	3500
FC29600	730	600	120	29.7	14.3	3800

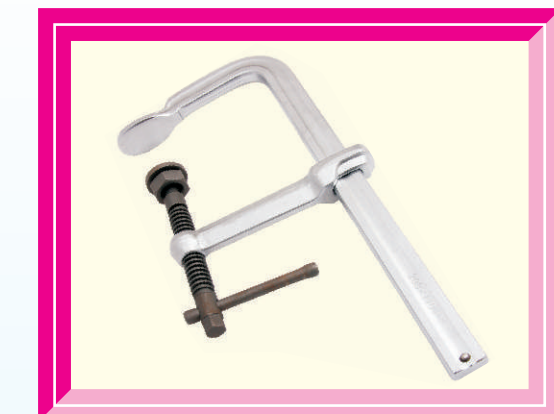

TAPARIA TOOLS LTD.



Head Office : 423 / 424, A-2, Shah & Nahar, Lower Parel (W), Mumbai - 400 013. & : 2493 8646 - 50
 Fax : 91-22-2495 3230. • E-mail : sales@tapariatools.com • Web Site : http://www.tapariatools.com
 Works : 52-B, M. I. D. C., Satpur, Nashik - 422 007. & : 2350 317 / 318 / 418 • Fax : 0253-2350740



An ISO-9001 Company

TAPARIA® TAPARIA® TAPARIA® TAPARIA® TAPARIA®

CROSS RIM WRENCH

Prod. No.	Size A/F	Length MM
CW0314	10 x 13 11 x 14	460
CW7981	17 x 19 18 x 21	460



COMBINATION SPANNERS

★ Made from chrome vanadium Steel.

★ Forged and accurately machined.

★ Hardened and tempered to give long trouble free service.

★ Provide with appropriate surface protection for rust prevention.



PROD. NO	D1	D2	T1	T2	L	WT. GMS
CS 06	11.0	13.0	5.5	4.5	100	18
CS 07	12.0	15.0	6.0	5.0	110	22
CS 08	14.0	18.0	6.5	5.0	120	25
CS 09	16.0	20.0	7.0	5.5	130	38
CS 10	18.0	22.0	7.5	5.5	140	45
CS 11	19.0	23.5	8.0	5.5	150	50
CS 12	20.0	25.5	8.5	6.0	160	55
CS 13	22.0	28.0	9.0	6.0	170	62
CS 14	23.5	30.5	9.5	7.0	180	80
CS 15	24.5	32.0	10.0	7.0	190	105
CS 16	25.5	34.0	10.5	7.5	200	120
CS 17	28.0	35.0	11.0	7.5	210	130
CS 18	28.5	37.0	11.5	7.5	220	155
CS 19	30.0	39.5	11.5	8.0	230	170
CS 20	30.5	42.0	12.0	8.0	240	190
CS 21	32.5	42.5	12.0	9.0	250	205
CS 22	34.0	45.0	13.0	10.0	260	220

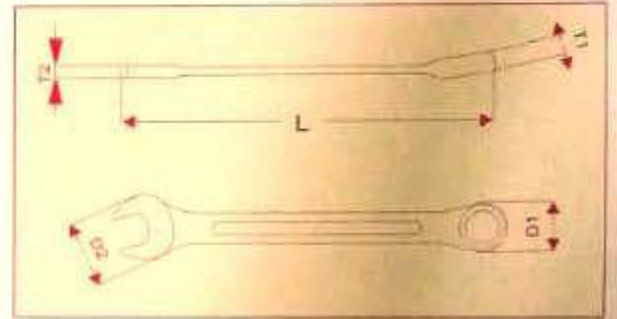

COMBINATION SPANNERS SETS

Prod. No.	Contents
CSS 6	8,10,12,13,14,17
CSS 8	8,9,10,11,13,14,17,19
CSS 12	6,7,8,9,10,11,12,13,14,17,19,20



TAPARIA TOOLS LTD.



Head Office : 423 / 424, A-2, Shah & Nahar, Lower Parel (W), Mumbai - 400 013. Tel : 6147 8600
 Fax : 91-22-2495 3230. • E-mail : sales@tapariatools.com • Web Site : http://www.tapariatools.com
 Works : 52-B, M. I. D. C., Satpur, Nashik - 422 007. & : 2350 317 / 318 / 418 • Fax : 0253-2350740



An ISO-9001 Company

TAPARIA® TAPARIA® TAPARIA® TAPARIA® TAPARIA®



TAPARIA TOOLS LTD.

AN ISO-9001 COMPANY



CUT-OFF WHEEL

GOLD SERIES

COWG 04
105X1.0X16mm



1. TAPARIA Cut off Wheels manufactured from high quality Aluminium Oxide.
2. Super thin Wheel for precise & fast cutting.
3. Double net for Safety.
4. Suitable for cutting metal & Stainless Steel.
5. TAPARIA Cut off wheels are value for money due to extra long cutting life.

Product	Net	Diameter	Bore	Thickness	Colours
COWG 04	2 net	105m	16m	1.0m	Black
COWG 2 GR04	2 Net	105m	16m	1.0m	Green
COWG 1 BL 14	1 Net	355m	25.4m	2.5m	Black
COWG 1 GR 14	1 Net	355m	25.4m	2.5m	Green
COWG 2 BL 14	2 Net	355m	25.4m	2.5m	Black



Plastic Runner Cutting Pliers

- TAPARIA Plastic Runner Cutting Pliers are specially designed to closely cut / separate the runner from the plastic moulded objects.

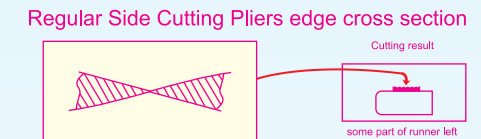
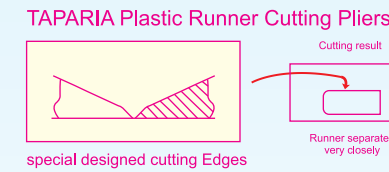

- These pliers can also be used to cut small plastic parts, remove the extra flash from moulded objects, etc..
- Precise matching of the cutting edges to prevent the cutting edges from damaging each other during use.
- Drop forged with high quality steel.
- Induction hardened cutting edges to enable long cutting life.
- Attractive and comfortable two colour plastic dipped handle Sleeves.
- Fitted with a Coil Spring to reduce hand fatigue, and increase efficiency.

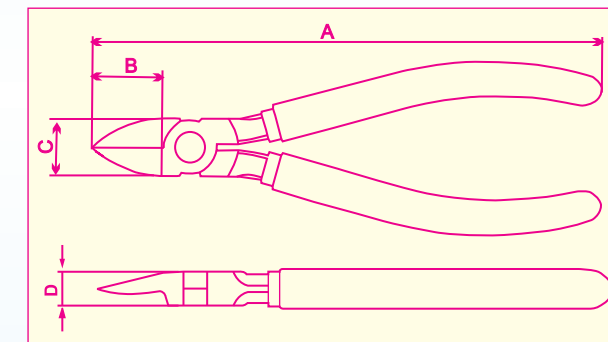
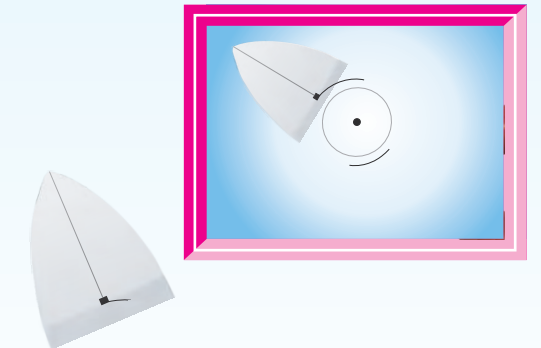

PRODUCT NO.	A	B	C	D	WEIGHT GRAMS
PCP - 06	157	20	18.6	10.5	150

TAPARIA TOOLS LTD.



Head Office : 423 / 424, A-2, Shah & Nahar, Lower Parel (W), Mumbai - 400 013. & : 6147 8600
Fax : 91-22-2495 3230. • **E-mail :** sales@tapariatools.com • **Web Site :** http://www.tapariatools.com
Works : 52-B, M. I. D. C., Satpur, Nashik - 422 007. & : 2350 317 / 318 / 418 • **Fax :** 0253-2350740



An ISO-9001 Company

TAPARIA® TAPARIA® TAPARIA® TAPARIA® TAPARIA®



TAPARIA TOOLS LTD.

AN ISO - 9001 COMPANY



BOLT CUTTERS, SPARE BLADE, CABLE CUTTERS, TIN CUTTERS WITH SPRING AND AVIATION TINMAN SNIPPER



BOLT CUTTER

- * Made from high-grade steel.
- * The jaws are forged and accurately machined.
- * The Cutting jaws are specially heat-treated for easy & click cutting of cutting wires, round steel bars, hard drawn steel wires & stranded wires.
- * The bolts and nuts used in the assembly of bolt cutter are hexagon type. Each bolt is firmly secured & cutting blades are suitably hardened & tempered and are ground to have sharp edge.
- * Handles are provided with sleeves to hold & operate smoothly with minimum effort.
- * Powder coating of handles provides good appearance as well as rust prevention.
- * The jaws are replaceable.
- * Available in various sizes.

CABLE CUTTER

- * Drop forged from high quality carbon steel.
- * Scientifically heat treated to give tough body.
- * The cutting edges are sharp and precision machined to appropriate angle to cut cables with ease.
- * PVC dip coated sleeve provides cushioning.

TIN CUTTER

- * Drop forged from high quality carbon steel.
- * Scientifically heat treated to give tough body.
- * The cutting edges are induction hardened.
- * The cutting edges are sharp and precision machined to appropriate angle to cut sheets with ease.
- * Provided with fixed stopper, which protects fingers from getting injured due to excessive closing of shanks.

BOLT CUTTERS

PROD. NO. & SIZE	A	CUTTING CAPACITY DIAMETER MAX.	WEIGHT GRAMS
BC - 8	200	4	275
BC - 12	300	5	800
BC - 14	350	6	980
BC - 18	450	7	1520
BC - 24	600	9	2430
BC - 30	750	12	3980
BC - 36	900	15	5580
BC - 42	1050	18	8140
BC - 48	1200	22	8500

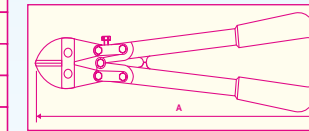

SPARE BLADES SET FOR BOLT CUTTERS

PRODUCT NO.	WEIGHT GRAMS
BCB - 12	218
BCB - 14	295
BCB - 18	480
BCB - 24	785
BCB - 30	1265
BCB - 36	1860
BCB - 42	2675
BCB - 48	2705



CABLE CUTTERS

PRODUCT NO.	A	B	C	D	MAX. CUT. CAP. (OD WITH PVC SLEEVE IN MM)	WEIGHT GRAMS
CC 06	160	20	26	10	9 mm	150
CC 08	210	22	29	13	10 mm	250
CC 10	240	30	34	15	15 mm	350
CCS 10	240	35	47	15	15 mm	470
CC 18	460	32	58	16	24 mm	1675
CC 24	600	35	64	17	27 mm	1790
CC 32	800	55	72	20	40 mm	4300

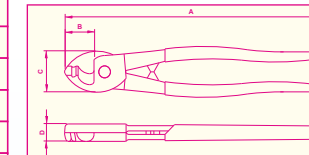

TIN CUTTERS WITH SPRING

PRODUCT NO.	A	B	C	D	CUTTING CAPACITY TIN THICKNESS MAX.	WEIGHT GRAMS
TCS 08	200	50	28	12	0.5 mm	250
TCS 10	250	60	32	14	0.75 mm	450
TCS 12	300	70	36	16	1.0 mm	650
TCS 14	350	85	42	18	1.25 mm	1000

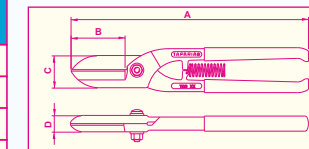

AVIATION TINMAN SNIPPERS

PRODUCT NO.	A	B	WEIGHT GRAMS
ATS 10 - Straight Nose	255	44	380
ATL 10 - Left Nose	250	44	350
ATR 10 - Right Nose	250	44	360

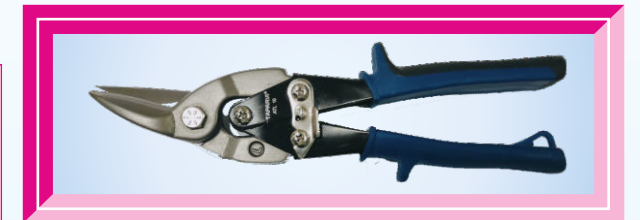
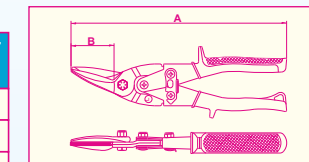

TAPARIA TOOLS LTD.



423 / 424, A-2, Shah & Nahar, Lower Parel (W), Mumbai - 400 013 (MH). ☎ : (022) 6147 8646.
 E-mail : htaparia@tapariatools.com, sales@tapariatools.com • Web Site : http://www.tapariatools.com
 Works : 52, M.I.D.C, Satpur, Nashik - 422 007 (MH), ☎ : (0253) 2350 317 / 18 / 418.
 E-mail : nashik@tapariatools.com. C.I.N. No. : L99999MH1965PLC013392



TAPARIA® TAPARIA® TAPARIA® TAPARIA® TAPARIA®



TAPARIA TOOLS LTD.

AN ISO-9001 COMPANY



DIAMOND BLADES

SEGMENTED CUT (DBS-4)



- Recommended for Marble, Kota Stone, Brick and Sand Stone.
- Sharp, efficient and long cutting life.
- Size 110mm.

CONTINUOUS CUT (DBC-4)

- Recommended for Clean and Chip Free Moulding
- Smooth and sharp cutting.
- size 110mm.



TURBO CUT (DBT-4)



- Recommended for Re-inforced Concrete, Tile and Granite.
- Smooth and sharp cutting.
- size 110mm.

SNAP OFF CUTTER



- ABS plastic body for higher strength and soft material for comfort in use.
- Blade made from high grade steel for sharp and long cutting.
- Ergonomically shaped body with soft grip for comfort in use.
- Twist locking system for enhanced safety.

Prod.No.	Blade Width mm	Std. Pkg.
SK-1	19	10 Pcs.

UTILITY KNIFE



- TAPARIA Utility Knife body is made from Die Cast Zinc for higher strength.
- Blades made from high grade steel for sharp and long cutting.
- Two extra spare blades provided inside the body.
- Ergonomically shaped body for comfort in cutting.

Prod.No.	Blade Width mm	Std. Pkg.
UK-3	19	6 Pcs.

SPARE BLADE FOR (UK-3)

Prod.No.	Blade Width mm	Std. Pkg.
UB-10	19	10 Pcs.

TAPARIA TOOLS LTD.



Head Office : 423 / 424, A-2, Shah & Nahar, Lower Parel (W), Mumbai - 400 013. Tel : 6147 8600
Fax : 91-22-2495 3230. ● **E-mail :** sales@tapariatools.com ● **Web Site :** http://www.tapariatools.com
Works : 52-B, M. I. D. C., Satpur, Nashik - 422 007. Tel : 2350 317 / 318 / 418 ● **Fax :** 0253-2350740



An ISO-9001 Company

TAPARIA® TAPARIA® TAPARIA® TAPARIA® TAPARIA®



TAPARIA TOOLS LTD.

AN ISO - 9001 COMPANY



SOCKET SETS in Blow Moulding Box 12.7 mm (1/2) Sq. Drive

* Socket and Accessories

- Made of high grade chrome vanadium steel.
- Scientifically heat treated to withstand high torque and long life.
- Bright Nickel Chrome plated to prevent from rusting and corrosion.
- Packed in compact and light weight Blow Moulding Box.

* The Blow Moulding Box is strong and durable.



Product No.		Contents
Bihexagonal Socket Set	Hexagonal Socket Set	
BMS14MXL (22 Sockets + 5 Accessories)	BMS14HXL	Sockets - 8,9,10,11,12,13,14,15,16,17,18,19, 21, 22, 23, 24, 26, 27, 28, 29, 30 & 32 Accessories - 1753, 1763, 1773, 1733, 1715
BMS15MXL (19 Sockets + 5 Accessories)	BMS15HXL	Sockets - 11, 12, 13, 14, 15, 16, 17, 18, 19, 21, 22, 23, 24, 26, 27, 28, 29, 30 & 32 Accessories - 1753, 1763, 1773, 1733, 1715
BMS17MXL (20 Sockets + 5 Accessories)	BMS17HXL	Sockets - 10, 11, 12, 13, 14, 15, 16, 17, 18, 19, 20, 21, 22, 23, 24, 27, 30 & 32 Spark Plug Socket: SP16 & SP21 Accessories - 1753, 1763, 1773, 1733, 1715

DEEP IMPACT SOCKETS - HEXAGONAL 12.7 mm (1/2) SQ. DRIVE

- * Made out of high grade Chrome Molybdenum steel.
- * Scientifically heat - treated to give maximum Impact strength, wear resistance and long trouble free service.
- * Black phosphate finish prevents rusting.
- * Good laser marking gives better visibility of the sizes.
- * Suitable for applications where more hexagonal depth is required to loosen the fastener.



Product No.	Fig. No.	A	B	C	ØD	ØE	A/F	WEIGHT GRAMS
IML 8H	1	78	30	48	15	25	8	110
IML 9H	1	78	30	48	16	25	9	120
IML 10H	1	78	30	48	18	25	10	125
IML 11H	1	78	30	48	18	25	11	122
IML 12H	1	78	30	48	19	25	12	132
IML 13H	1	78	30	48	20	25	13	135
IML 14H	1	78	30	48	22	25	14	150
IML 15H	1	78	30	48	23	25	15	152
IML 16H	1	78	30	48	24	25	16	155
IML 17H	1	78	30	48	26	30	17	225
IML 18H	1	78	30	48	27	30	18	226
IML 19H	1	78	30	48	28	30	19	230
IML 20H	1	78	30	48	29	30	20	230
IML 21H	2	78	--	--	30	--	21	235
IML 22H	3	78	30	48	32	30	22	260
IML 23H	3	78	30	48	34	30	23	285
IML 24H	3	78	30	48	34	30	24	275
IML 27H	3	78	30	48	38	30	27	315
IML 32H	3	78	20	58	44	32	32	420

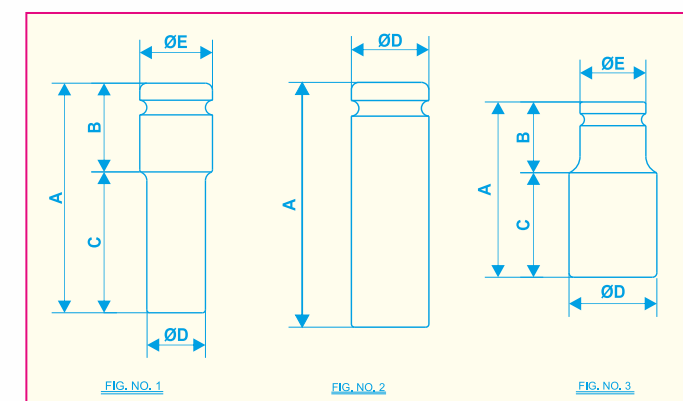

TAPARIA TOOLS LTD.

423 / 424, A-2, Shah & Nahar, Lower Parel (W), Mumbai - 400 013 (MH). ☎ : (022) 6147 8646.
 E-mail : htaparia@tapariatools.com, sales@tapariatools.com • Web Site : http://www.tapariatools.com
 Works : 52, M.I.D.C, Satpur, Nashik - 422 007 (MH), ☎ : (0253) 2350 317 / 18 / 418.
 E-mail : nashik@tapariatools.com. C.I.N. No. : L99999MH1965PLC013392



TAPARIA® TAPARIA® TAPARIA® TAPARIA® TAPARIA®



TAPARIA TOOLS LTD.

AN ISO-9001 COMPANY



STEEL FILES

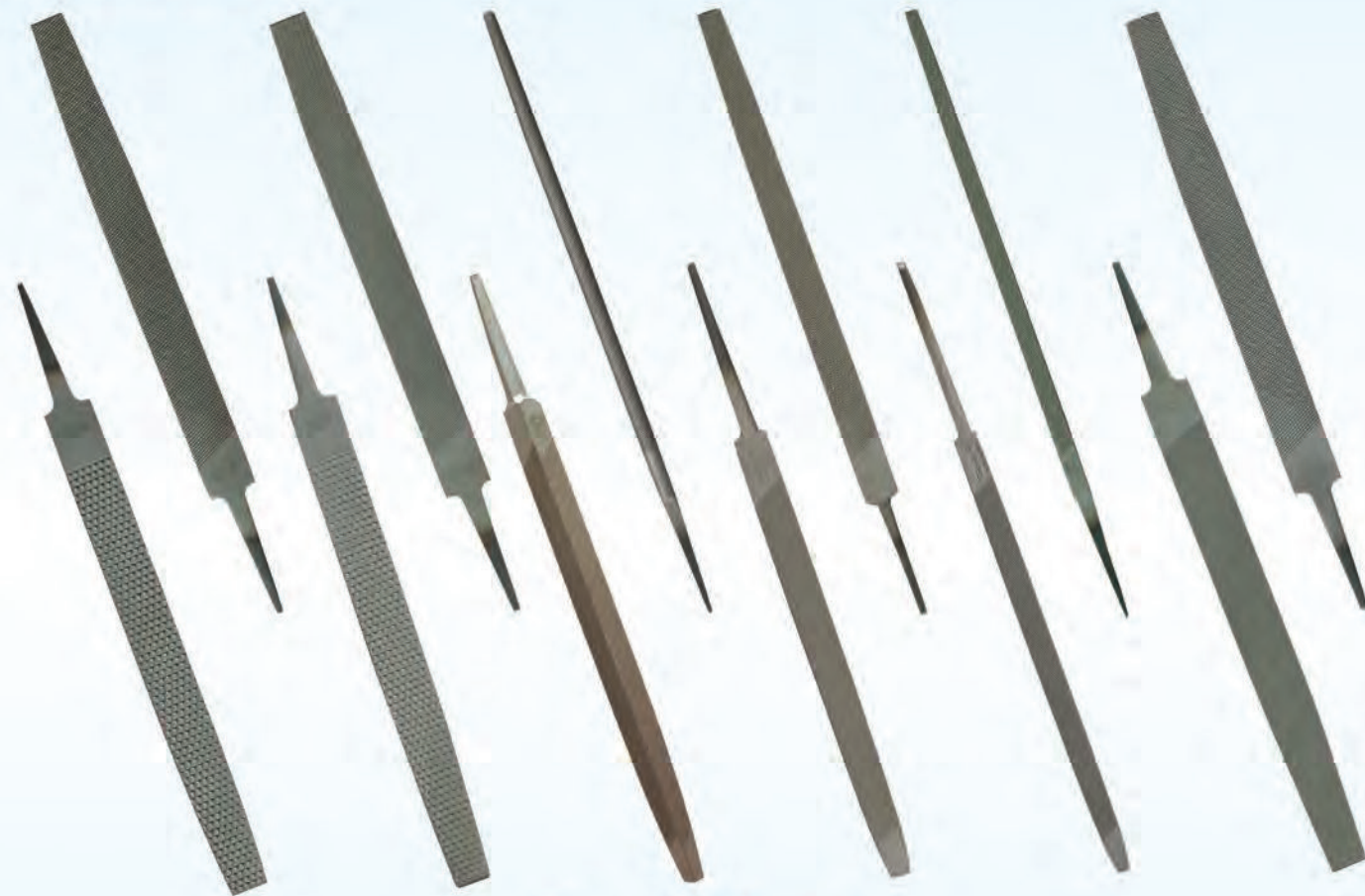

Choosing The Right File

File Cut

Shapes	Type of files
	Hand, Flat, Flat Rasp, Mill
	Half, Halfround Pointed, Halfround Rasp.
	Triangular, Saw Regular, Saw Slim, Saw Extra Slim, Saw double extra slim.
	Round, Round Rasp
	Square

- Single Cut - Single Cut files (mostly all Saw Files are Single Cut) are used for sharpening and edging applications. e.g. Sharpening of saws where the work piece is hard, point of contact is less and finish is required.
- Double Cut - Double Cut files need less effort for filing and also give good surface finish.
- Bastard Cut - for stock removal and coarse finish.
- Second Cut - for moderate stock removal and medium to coarse finish.
- Smooth Cut - for smooth surface finish.
- Rasp Cut - special cut formation for rapid stock removal from surface or softer materials like wood or leather.

- Tips :**
- A new file should be used with light pressure in the beginning, preferably on a surface which has been filed earlier.
 - In case of clogging of file teeth, clean the teeth with a soft metal wire brush.
 - Use the files for cutting in the forward stroke only.
 - Filing jobs should be held rigidly.

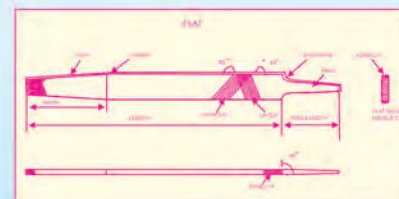

STEEL FILES

34. (A) MACHINIST'S FILES

Size MM	FLAT						
	Bastard	Price Each ₹	2nd Cut	Price Each ₹	Smooth	Price Each ₹	Std. Pkg.
100	FL 1001	133	FL 1002	163	FL 1003	185	10
150	FL 1501	135	FL 1502	185	FL 1503	204	10
200	FL 2001	136	FL 2002	215	FL 2003	232	10
250	FL 2501	138	FL 2502	226	FL 2503	285	10
300	FL 3001	210	FL 3002	334	FL 3003	371	5
350	FL 3501	473	FL 3502	499	FL 3503	549	5

Size MM	ROUND						
	Bastard	Price Each ₹	2nd Cut	Price Each ₹	Smooth	Price Each ₹	Std. Pkg.
100	RD 1001	170	RD 1002	195	RD 1003	221	10
150	RD 1501	198	RD 1502	209	RD 1503	225	10
200	RD 2001	222	RD 2002	226	RD 2003	260	10
250	RD 2501	288	RD 2502	301	RD 2503	324	10
300	RD 3001	357	RD 3002	380	RD 3003	420	5
350	RD 3501	502	RD 3502	525	RD 3503	575	5

Size MM	THREE SQUARE						
	Bastard	Price Each ₹	2nd Cut	Price Each ₹	Smooth	Price Each ₹	Std. Pkg.
100	3SQ 1001	200	3SQ 1002	216	3SQ 1003	223	10
150	3SQ 1501	214	3SQ 1502	225	3SQ 1503	251	10
200	3SQ 2001	284	3SQ 2002	300	3SQ 2003	320	10
250	3SQ 2501	379	3SQ 2502	401	3SQ 2503	430	10
300	3SQ 3001	479	3SQ 3002	503	3SQ 3003	528	5
350	3SQ 3501	644	3SQ 3502	672	3SQ 3503	700	5

Size MM	HAND						
	Bastard	Price Each ₹	2nd Cut	Price Each ₹	Smooth	Price Each ₹	Std. Pkg.
100	HF 1001	133	HF 1002	163	HF 1003	185	10
150	HF 1501	135	HF 1502	185	HF 1503	204	10
200	HF 2001	136	HF 2002	215	HF 2003	232	10
250	HF 2501	138	HF 2502	226	HF 2503	285	10
300	HF 3001	210	HF 3002	334	HF 3003	371	5
350	HF 3501	473	HF 3502	499	HF 3503	549	5

Size MM	HALF ROUND						
	Bastard	Price Each ₹	2nd Cut	Price Each ₹	Smooth	Price Each ₹	Std. Pkg.
100	HR 1001	250	HR 1002	270	HR 1003	282	10
150	HR 1501	278	HR 1502	298	HR 1503	319	10
200	HR2001	354	HR2002	390	HR 2003	415	10
250	HR 2501	450	HR 2502	526	HR 2503	554	10
300	HR 3001	605	HR 3002	633	HR 3003	689	5
350	HR 3501	756	HR 3502	819	HR 3503	865	5

Size MM	SQUARE						
	Bastard	Price Each ₹	2nd Cut	Price Each ₹	Smooth	Price Each ₹	Std. Pkg.
100	SQ 1001	195	SQ 1002	206	SQ 1003	215	10
150	SQ 1501	209	SQ 1502	215	SQ 1503	226	10
200	SQ 2001	216	SQ 2002	226	SQ 2003	252	10
250	SQ 2501	288	SQ 2502	301	SQ 2503	323	10
300	SQ 3001	357	SQ 3002	380	SQ 3003	428	5
350	SQ 3501	474	SQ 3502	510	SQ 3503	521	5

34. (B) SAW FILES

Size MM	HEAVY TAPER				REGULAR TAPER			SLIM TAPER			MILL FILES			
	Prod.No.	Price Each ₹	Std. Pkg.		Prod.No.	Price Each ₹	Std. Pkg.	Prod.No.	Price Each ₹	Std. Pkg.	Size MM	Bastard	Price Each ₹	Std. Pkg.
100	HT 1002	40	10		RT 1002	40	10	ST 1002	42	10	200	MF 2001	109	10
125	HT 1252	57	10		RT 1252	57	10	ST 1252	50	10	250	MF 2501	110	10
150	HT 1502	74	10		RT 1502	74	10	ST 1502	52	10	300	MF 3001	152	5
200	HT 2002	105	10											

Size MM	FLAT SUPER LIGHT				PIT SAW	
	Bastard	Price Each ₹	2nd Cut	Price Each ₹	Std. Pkg.	Std. Pkg.
	FLSL 2501	109	FLSL 2502	110	10	
113						PS 1102
						52
						10

34. (C) WOOD RASPS FILES

Size MM	FLAT WOOD RASP						
	Bastard	Price Each ₹	2nd Cut	Price Each ₹	Smooth	Price Each ₹	Std. Pkg.
150	FLRP 1501	215	FLRP 1502	216	FLRP 1503	225	10
200	FLRP 2001	291	FLRP 2002	300	FLRP 2003	311	10
250	FLRP 2501	340	FLRP 2502	365	FLRP 2503	382	10

Size MM	HALF ROUND WOOD RASP						
	Bastard	Price Each ₹	2nd Cut	Price Each ₹	Smooth	Price Each ₹	Std. Pkg.
150	HRRP 1501	252	HRRP 1502	259	HRRP 1503	266	10
200	HRRP 2001	321	HRRP 2002	324	HRRP 2003	337	10
250	HRRP 2501	381	HRRP 2502	400	HRRP 2503	402	10

TAPARIA TOOLS LTD.



Head Office : 423 / 424, A-2, Shah & Nahar, Lower Parel (W), Mumbai - 400 013. Tel : 6147 8600
 Fax : 91-22-2495 3230. • E-mail : sales@tapariatools.com • Web Site : http://www.tapariatools.com
 Works : 52-B, M. I. D. C., Satpur, Nashik - 422 007. Tel : 2350 317 / 318 / 418 • Fax : 0253-2350740



An ISO-9001 Company

TAPARIA® TAPARIA® TAPARIA® TAPARIA® TAPARIA®



TAPARIA TOOLS LTD.

AN ISO-9001 COMPANY



GEAR PULLERS

- ★ Drop forged with high grade steel.
- ★ Accurately hardened and tempered to withstand high torque.
- ★ The center screw is provided with a special adjustable cap for better gripping.
- ★ The Jaws, link plates, protective cap and connecting bolts are plated.

PROD. NO.		Size
BP 203	2 Legs	3"
BP 204	2 Legs	4"
BP 303	3 Legs	3"
BP 304	3 Legs	4"
BP 306	3 Legs	6"
BP 308	3 Legs	8"



TAPARIA TOOLS LTD.

Head Office : 423 / 424, A-2, Shah & Nahar, Lower Parel (W), Mumbai - 400 013. Tel : 6147 8600
Fax : 91-22-2495 3230. • **E-mail :** sales@tapariatools.com • **Web Site :** http://www.tapariatools.com
Works : 52-B, M. I. D. C., Satpur, Nashik - 422 007. Tel : 2350 317 / 318 / 418 • **Fax :** 0253-2350740

An ISO 9001 Company



TAPARIA TAPARIA TAPARIA TAPARIA TAPARIA



TAPARIA TOOLS LTD.

AN ISO-9001 COMPANY



GREASE GUN BARREL



Special Features:

- * Grease Gun Barrel made from high quality steel sheet of 1.2 mm thickness.
- * Knurled barrel for better grip.
- * Grease gun head made from Aluminium die casting / cast iron for better life.
- * Rolled threads for fast & easy loading & unloading of gun head for re-filling of grease.
- * Lever assisted fabricated handles with soft grip for comfortable usage.
- * Spring loaded plunger rod with Delta handle for operating ease.
- * Provided with steel spout with 'four-jaw' coupler.
- * Can be used with hose extension & with different greasing nipples.

Surface Finish:

- * Body: Powder coated in cyan blue colour with smooth & glossy finish.
- * Plunger: Bright Ni-Cr plated.

Applications:

- * Farm Equipments
- * Earth Moving Equipments
- * Automobile./ vehicles.
- * Machineries & Industrial applications.
- * Garages & Workshops.

Available in different capacities.

GREASE GUN BARREL

Tech Details:

S.N.	Models -->	GGL20C	GGL30C	GGL45C	GGL45E	GGL45F
1	Capacity	200 cc	300 cc	445 cc	445 cc	445 cc
2	Piston size	11/32 (8.6 mm)	11/32 (8.6 mm)	11/32 (8.6 mm)	1/2 (12.7 mm)	5/8 (15.8 mm)
3	Pressure (psi)	5000	5000	8000	2000	2000
4	Gun Head	Aluminium casting	Aluminium casting	Aluminium casting	Cast iron	Aluminium casting



TAPARIA TOOLS LTD.

Head Office : 423 / 424, A-2, Shah & Nahar, Lower Parel (W), Mumbai - 400 013. & : 6147 8600
 Fax : 91-22-2495 3230. • E-mail : sales@tapariatools.com • Web Site : http://www.tapariatools.com
 Works : 52-B, M. I. D. C., Satpur, Nashik - 422 007. & : 2350 317 / 318 / 418 CIN : L99999MH1965PLC013392



AN ISO-9001 - 2015 COMPANY

TAPARIA® TAPARIA® TAPARIA® TAPARIA® TAPARIA®



TAPARIA TOOLS LTD.

AN ISO - 9001 COMPANY



HACKSAW BLADES



Carbon Steel All Hard

Product No.	Description	Std. Pkg.
HBHC 1218	Carbon Steel All Hard (18 TPI)	100
HBHC 1224	Carbon Steel All Hard (24 TPI)	100

Bi - Metal

Product No.	Description	Std. Pkg.
HBB 1218	HSS Bi-Metal (18 TPI)	10
HBB 1224	HSS Bi-Metal (24 TPI)	10

HSS All Hard

Product No.	Description	Std. Pkg.
HSS 1218	HSS All Hard (18 TPI)	10
HSS 1224	HSS All Hard (24 TPI)	10

Carbon Steel (Double Side Cutting)

Product No.	Description	Size	Std. Pkg.
HBCD 118	18 TPI	300 x 25 x 0.63	50
HBCD 124	24 TPI	300 x 25 x 0.63	50

TAPARIA TOOLS LTD.

423 / 424, A-2, Shah & Nahar, Lower Parel (W), Mumbai - 400 013 (MH). ☎ : (022) 6147 8646.

E-mail : htaparia@tapariatools.com, sales@tapariatools.com • Web Site : <http://www.tapariatools.com>

Works : 52, M.I.D.C, Satpur, Nashik - 422 007 (MH), ☎ : (0253) 2350 317 / 18 / 418.

E-mail : nashik@tapariatools.com. C.I.N. No. : L99999MH1965PLC013392



TAPARIA® TAPARIA® TAPARIA® TAPARIA® TAPARIA®



TAPARIA TOOLS LTD.

AN ISO - 9001 COMPANY



HAMMERS

- * Available in Ball Pein, Cross Pein and Claw version.
- * Head drop forged made from high grade steel.
- * Head differentially heat treated to ensure safe use.



HAMMER WITH HANDLE (BALL PEIN & CROSS PEIN)

PROD. NO	A	B	ØC	ØD	WT. GMS
WH110B	260	64	18	20	170
WH200B	300	80	20	25	325
WH340B	315	90	26	28	425
WH500B	330	105	25	30	710
WH600B	375	110	30	35	815
WH800B	375	120	32	40	1050

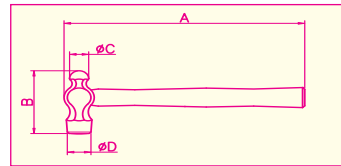

PROD. NO	A	B	C	ØD	WT. GMS
WH200C	310	86.5	18	25	330
WH500C	330	105	25	31.5	800
WH800C	375	120	32	40	1050

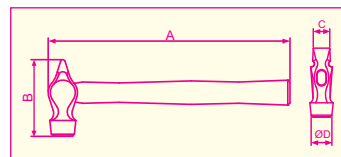

CLAW HAMMER WITH HANDLE

PROD. NO	A	B	ØC	WT. GMS
CH 340	310	120	28	510
CLH 450	330	131	31	645

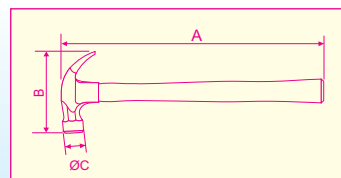

ELECTRICIAN HAMMER WITH HANDLE

PROD. NO	A	B	ØC	WT. GMS
SQ 15	280	140	15	250

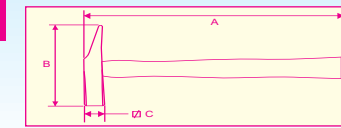

MACHINIST HAMMER WITH HANDLE

PROD. NO	A	B	ØC	WT. GMS
MH 100	260	85	15	160
MH 200	280	95	19	270
MH 300	300	105	22	430
MH 400	310	115	25	510
MH 500	320	120	27	600

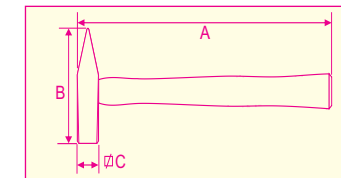

CLUB HAMMER WITH HANDLE

PROD. NO	A	B	C	WT. GMS
GH 800	250	92	36	950
GH 1000	260	96	38	1150
GH 1250	260	102	42	1400
GH 1500	260	110	44	1650

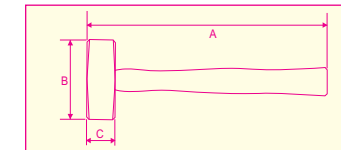

SLUDGE HAMMER HEAD

PROD. NO	B	C	WT. GMS
SHH 900	105	36	900
SHH 1350	120	42	1350
SHH 1800	133	46	1800
SHH 2700	155	54	2700
SHH 3600	168	58	3600
SHH 4500	174	64	4500
SHH 5400	184	68	5400
SHH 6300	195	72	6300
SHH 7200	204	74	7200
SHH 8100	208	78	8100
SHH 9000	216	82	9000

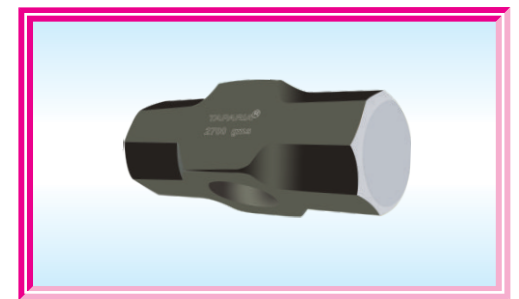
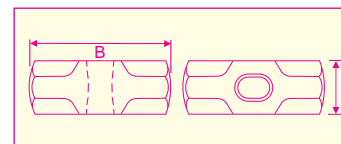

SLUDGE HAMMER WITH HICKORY WOOD HANDLE

PROD. NO	A	B	C	WT. GMS
SHHW - 1350	400	115	44	1500
SHHW - 1800	770	130	48	2350
SHHW - 3600	770	165	60	4100
SHHW - 5400	770	190	68	6150
SHHW - 6300	770	198	72	6750

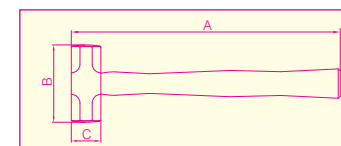

SOFT FACED HAMMER WITH HANDLE

- * The Soft Mallet Hammers are available in 20mm, 25mm, 30mm, 40mm & 50mm sizes.

* TAPARIA will also offer spares for these Soft Mallet Hammers.

Prod. No.	A	B	ØD	WT. GMS
SFH 20	272	74	20	240
SFH 25	272	90	25	320
SFH 30	272	90	30	425
SFH 40	330	122	40	800
SFH 50	330	124	50	1120

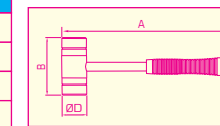

SOFT FACE HAMMER SPARES

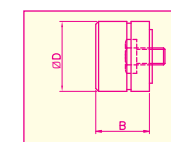

Prod. No.	B	ØD	WT. GMS
SFH 20 S	20	20	12
SFH 25 S	26	25	25
SFH 30 S	30	30	46
SFH 40 S	38	40	90
SFH 50 S	38	50	130



TAPARIA TOOLS LTD.

423 / 424, A-2, Shah & Nahar, Lower Parel (W), Mumbai - 400 013 (MH). ☎ : (022) 6147 8646.

E-mail : htaparia@tapariatools.com, sales@tapariatools.com • Web Site : http://www.tapariatools.com

Works : 52, M.I.D.C, Satpur, Nashik - 422 007 (MH), ☎ : (0253) 2350 317 / 18 / 418.

E-mail : nashik@tapariatools.com. C.I.N. No. : L99999MH1965PLC013392



TAPARIA® TAPARIA® TAPARIA® TAPARIA® TAPARIA®



TAPARIA TOOLS LTD.

AN ISO - 9001 COMPANY



HYDRAULIC BOTTLE JACK, HYDRAULIC TROLLEY JACK AND JACK STAND

HYDRAULIC BOTTLE JACK

- * It occupies less space and easy to use.
- * Compact and Rigid Structure.
- * Superior Hydraulic Fluid is used in the Jack.
- * Sturdy Steel base structure to avoid Fluid Leakages.
- * High Grade Steel is used to make the Bottle.
- * It works in all weather conditions.
- * All the Bottle Jacks are powder coated to prevent corrosion.
- * It's Application in Automobile Garages and Work Station, Cars & Trucks and Industries.



Product Code	Capacity (Ton)	Min Height (mm)	Lift Height (mm)	Adjustable Height (mm)	Total Expanded Height (mm)	NW/GW (kg)
HBJ - 2	2	178	112	48	338	2.08/2.18
HBJ - 3	3	188	115	60	363	2.82/2.97
HBJ - 5	5	207	125	70	402	3.72/3.92
HBJ - 8	8	222	145	80	447	4.7/4.84
HBJ - 10	10	222	145	80	447	4.7/4.84
HBJ - 12	12	227	150	80	457	6/6.12
HBJ - 16	16	227	150	80	457	6.97/7.07
HBJ - 20	20	235	150	60	445	8.78/8.98
HBJ - 32	32	260	160	-	420	17.8/18.05
HBJ - 50	50	280	170	-	450	25.8/26.05

HYDRAULIC TROLLEY JACK

- * Easy to use.
- * Reliable, compact and rigid structure.
- * Good Quality hydraulic fluid used in the jacks to ensure appropriate lift.
- * Powder coating provided on the surface to prevent rust and ensure long life.
- * Castor wheel attached for ease in mobility around the work place.
- * Easily portable and precise mechanism used to ensure smooth working.
- * Wider saddle for greater stability.
- * Durable wheels Trolley jack with handle.
- * Great for cars and light trucks.

Product Code	Capacity (Ton)	Min Height (mm)	Max Height (mm)	NW/GW (kg)
HTJ - 1.5	1.5	130	300	6.8/7.5
HTJ - 2	2	135	340	8.7/9.4
HTJ - 3	3	135	400	16.4/17



JACK STAND

- * Sturdy and rigid design, made with best quality material, with floor base which makes it more stable and dependable.
- * High compressive strength to withstand the rated load.
- * Locking lever provided to lock the height of the lift arm at desired level.
- * Powder coated finish gives rich look and prevents rust on the surface.
- * Always use jack stand in pair.
- * Bigger saddle area is provided for greater stability.
- * Stand can be raised or lowered to the height needed self-locking ratchet for ease of use.

Product Code	Capacity (Ton)	Min Height (mm)	Max Height (mm)	NW/GW (kg)
JS - 3	3	276	420	6.6/7.1



TAPARIA TOOLS LTD.



423 / 424, A-2, Shah & Nahar, Lower Parel (W), Mumbai - 400 013 (MH). ☎ : (022) 6147 8646.
 E-mail : htaparia@tapariatools.com, sales@tapariatools.com • Web Site : http://www.tapariatools.com
 Works : 52, M.I.D.C, Satpur, Nashik - 422 007 (MH), ☎ : (0253) 2350 317 / 18 / 418.
 E-mail : nashik@tapariatools.com. C.I.N. No. : L99999MH1965PLC013392



TAPARIA® TAPARIA® TAPARIA® TAPARIA® TAPARIA®



TAPARIA TOOLS LTD.

AN ISO-9001 COMPANY



MAGNETIC PRODUCTS

1341 Mini Magnetic Tray 150mm (6")



1343 Rectangular Magnetic Tray With 2 Magnets



- ★ TAPARIA Magnetic Tray is made from high quality stainless steel to ensure high strength and to resist corrosion.
- ★ A strong and powerful permanent magnet provided in the base of the tray is covered with protective rubber coating which prevents damage to the surfaces also on which the tray is fixed or placed.
- ★ The Magnetic Tray can hold parts and tools firmly in all and any position including tilted, sloping or upside down position.
- ★ TAPARIA Magnetic Tray is ideal for use in Garages, Workshops, House hold works...etc. These bowls can firmly retain any small screws, nuts, tools, pins or any other iron/steel objects.
- ★ This Magnetic Tray provides ease in operation and is a convenient helper which ensures that no part small or big is lost, damaged or even spoiled due to dust, oil, grease etc. It enhances efficiency and reduces loss of time due to cleaning dropped parts or locating lost parts etc.



139201 Magnetic Charger

- ★ TAPARIA Magnetic Charger can be used for magnetizing many steel items including screwdriver blades, metal rods etc.
- ★ The same can be also be used for demagnetizing those objects.
- ★ The magnetic charger is encased in a red PVC body which not only protects the same but also looks aesthetically decent.

139202 Magnetic Wrist Collector



- ★ TAPARIA Magnetic Wrist collector is worn on the wrist like a watch and is a very convenient tool wherever applicable for holding all types of fastener (nuts, bolts, nails etc), small part, clips etc close at hand while working.
- ★ TAPARIA Magnetic Wrist collector provides ease in operation and a convenient helper which ensures that no part small or big is lost, damaged or even spoiled due to dust, oil, grease etc. It enhances efficiency and reduces loss of time due to cleaning dropped parts, locating lost parts etc.
- ★ The Adjustable wrist straps make it convenient to be worn on all sizes of wrist.
- ★ The magnet is encased in high quality stainless steel to ensure high strength and to resist corrosion.

139101 Magnetic Quick Clamp

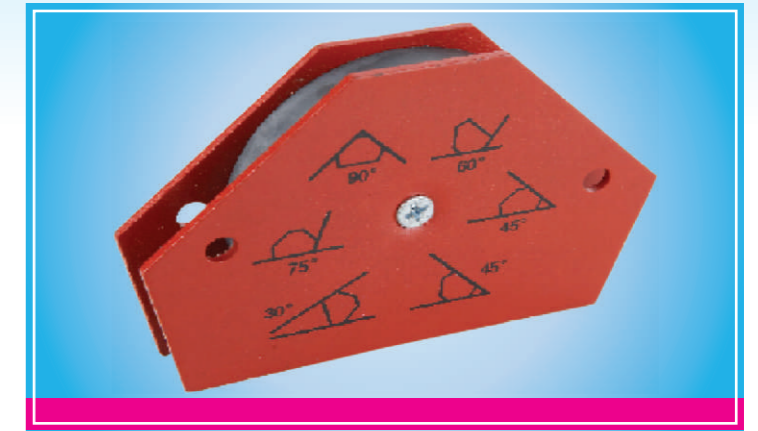

- ★ TAPARIA Magnetic Quick Clamp is suitable for holding iron and steel products at various angles of 30°, 45°, 60°, 75°, 90°...etc.
- ★ Strong and powerful permanent magnets can hold any iron/steel objects together for any further operation like welding etc.
- ★ Leaves both your hands free for welding, assembly, soldering, etc.
- ★ The TAPARIA Magnetic Quick Clamp is an innovative and extremely useful product which frees both hands for welding, soldering, assembly of angles, steel plates, pipes and other steel and iron products.

Telescopic Magnetic Bar



- ★ The powerful small size magnet can lift upto 1 Kg. Load
- ★ The telescopic design gives flexibility to use from 130 mm length in closed position to 620 mm length in open position
- ★ Can be used conveniently in confined spaces because of the slim design
- ★ Provided with a clip for keeping in pocket

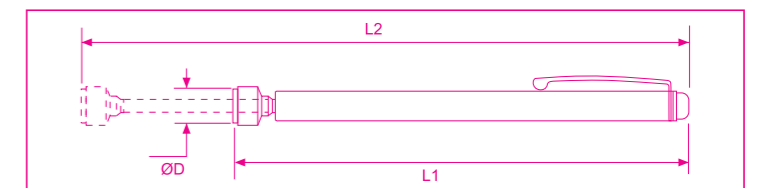

PPOD. NO.	ØD	L1	L2	WT. GMS	LIFTING CAPACITY
MB 6201	10	130	620	35	1 Kg.

TAPARIA TOOLS LTD.



Head Office : 423 / 424, A-2, Shah & Nahar, Lower Parel (W), Mumbai - 400 013. Tel : 6147 8600
 Fax : 91-22-2495 3230. • E-mail : sales@tapariatools.com • Web Site : http://www.tapariatools.com
 Works : 52-B, M. I. D. C., Satpur, Nashik - 422 007. Tel : 2350 317 / 318 / 418 • Fax : 0253-2350740



An ISO-9001 Company

TAPARIA® TAPARIA® TAPARIA® TAPARIA® TAPARIA®



TAPARIA TOOLS LTD.

AN ISO-9001 COMPANY



Masonry Drill Bits



Masonry Drill Bits

- Taparia Masonry Drill Bits use high quality Tungsten Carbide Tips to enable long and consistent drilling.
- Masonry Drill Bits are having fully hardened body to avoid bending of the drill during use and for longer life.
- Masonry Drill Bits are with straight shank.
- Useful for drilling holes in concrete, masonry and brick applications.

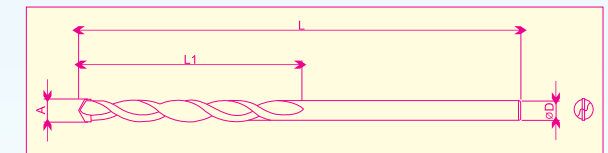

PROD. NO	A (Drill Size)	Ø D	L1	L	WT. GMS
MD 360	3	2.7	30	60	2.5
MD 470	4	3.5	35	70	4.5
MD 585	5	4.5	45	85	8
MD 55100	5.5	5	60	100	12
MD 6100	6	5	60	100	12
MD 6150	6	5	90	150	19
MD 7100	7	6	55	100	18
MD 8110	8	7	60	110	27
MD 9150	9	8.5	90	150	52
MD 10150	10	8.5	90	150	52
MD 11150	11	9.5	90	150	64
MD 12150	12	9.5	90	150	64
MD 13150	13	10	85	150	82



TAPARIA TOOLS LTD.



Head Office : 423 / 424, A-2, Shah & Nahar, Lower Parel (W), Mumbai - 400 013. Tel : 6147 8600
 Fax : 91-22-2495 3230. • E-mail : sales@tapariatools.com • Web Site : http://www.tapariatools.com
 Works : 52-B, M. I. D. C., Satpur, Nashik - 422 007. Tel : 2350 317 / 318 / 418 • Fax : 0253-2350740



An ISO-9001 Company

TAPARIA® TAPARIA® TAPARIA® TAPARIA® TAPARIA®



TAPARIA TOOLS LTD.

AN ISO-9001 COMPANY



MINI PLIERS



- ★ Made from high grade carbon steel.
- ★ Springs provided between legs.
- ★ Dip Coated sleeves.

Flat Nose Mini Plier - 1401

PROD. NO.	A	B	C	D	E	F	WT. GMS
1401	125	28	--	12	6.5	--	60

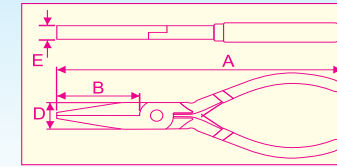

Round Nose Mini Plier - 1402

PROD. NO.	A	B	C	D	E	F	WT. GMS
1402	125	28	--	12	6.5	2.0	55

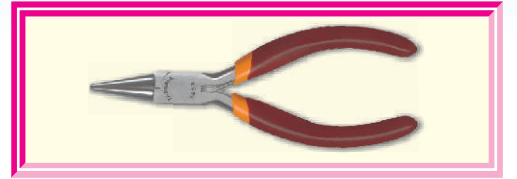
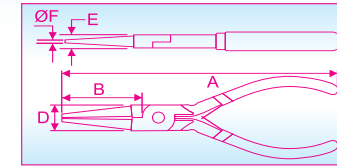

Long Nose Mini Plier - 1403

PROD. NO.	A	B	C	D	E	F	WT. GMS
1403	125	35	8	12	6.5	1.5	55

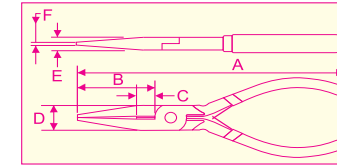

Bent Nose Mini Plier - 1404

PROD. NO.	A	B	C	D	E	F	WT. GMS
1404	125	--	--	12	6.5	13	60

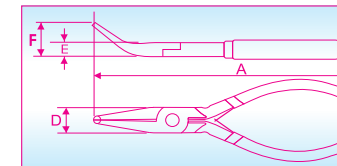

Side Cutting Mini Plier - 1405

PROD. NO.	A	B	C	D	E	F	WT. GMS
1405	125	16	--	12	6.5	--	60

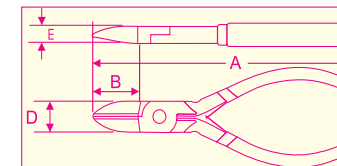

End Cutting Mini Plier - 1406

PROD. NO.	A	B	C	D	E	F	WT. GMS
1406	110	8	--	18	13	--	70

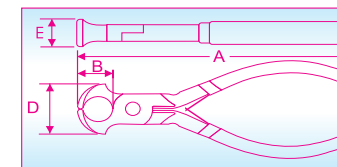

Combination Mini Plier - 1407

PROD. NO.	A	B	C	D	E	F	WT. GMS
1407	125	19	--	17	9.5	--	110

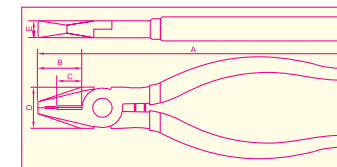

Long Needle Nose Mini Plier - 1408

PROD. NO.	A	B	C	D	E	F	WT. GMS
1408	150	55	--	11.5	6	2.5	60

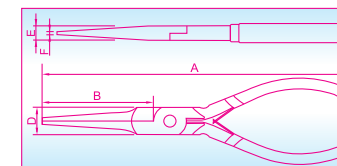

Long Needle Bend Nose Mini Plier - 1409

PROD. NO.	A	B	C	D	E	F	WT. GMS
1409	145	--	--	12	6	12	60

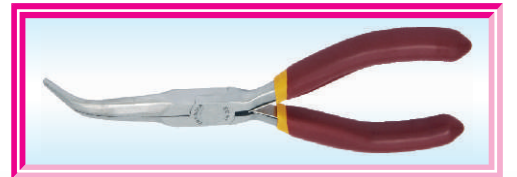
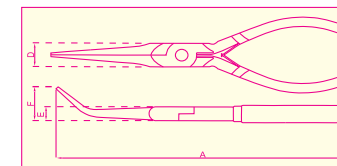

TAPARIA TOOLS LTD.



Head Office : 423 / 424, A-2, Shah & Nahar, Lower Parel (W), Mumbai - 400 013. & : 2493 8646 - 50
 Fax : 91-22-2495 3230. • E-mail : sales@tapariatools.com • Web Site : http://www.tapariatools.com
 Works : 52-B, M. I. D. C., Satpur, Nashik - 422 007. & : 2350 317 / 318 / 418 • Fax : 0253-2350740



An ISO-9001 Company

TAPARIA® TAPARIA® TAPARIA® TAPARIA® TAPARIA®

NON SPARKING TOOLS

- TAPARIA Non-Sparking Safety Tools provide protection against Fire and explosions.
- These tools are non-magnetic and corrosion-resistant.
- They protect workmen and plant from fire related accidents.
- They are tested and approved by Govt. recognized laboratory in India.
- TAPARIA Non-sparking Tools are made of beryllium Copper and Alluminium Bronze.



The Catalogue and Quotation for the same will be forwarded on request.

TAPARIA TOOLS LTD.



Head Office : 423 / 424, A-2, Shah & Nahar, Lower Parel (W), Mumbai - 400 013. & : 2493 8646 - 50
Fax : 91-22-2495 3230. • **E-mail :** sales@tapariatools.com • **Web Site :** <http://www.tapariatools.com>
Works : 52-B, M. I. D. C., Satpur, Nashik - 422 007. & : 2350 317 / 318 / 418 • **Fax :** 0253-2350740



An ISO-9001 Company

TAPARIA® TAPARIA® TAPARIA® TAPARIA® TAPARIA®



TAPARIA TOOLS LTD.

AN ISO-9001 COMPANY



Oil Cans

High Pressure Metal Oil Cans - Wesco Type

- Oil can body made from heavy gauge tin coated sheet.
- Good quality powder coating finish for rust protection.
- The Pump mechanism is fitted with two steel balls which delivers large volume of oil in each pumping stroke.
- The suction tube at bottom of the pump is without spring high prevents small functioning.
- Detachable rigid spout.
- The suction tube at bottom of the pump is without spring, which prevents mal-functioning.



PROD. NO	Capacity	Spout length
OC 14	1/4 Pint 125cc	125mm
OC 12	1/4 Pint 250 cc	150mm
OC 34	3/4 Pint 375 cc	150mm
OC 1	1 Pint 500 cc	165mm



Bevelled Edge Chisels

- Ergonomic handle design with soft Grip.
- Steel cap to protect the handle from damage during hammer strikes.
- High grade alloy steel blade for sharp & long cutting.
- High hardness till 2/3rd of blade length for longer cutting edge life after re-sharpening.
- Pre-Sharpened cutting edge for immediate use.
- Suitable blade cutting angle for the best cutting performance.
- **Anti rust coating on the steel blade.**

PROD. NO	Size	A	B	C	L	WEIGHT GRAMS
WCB06	6 (1/4")	135	6	33	260	155
WCB08	8 (5/16)	135	8	33	260	165
WCB10	10 (3/8)	135	10	33	260	170
WCB12	12 (1/2)	135	12	33	260	175
WCB19	19 (3/4)	135	19	33	260	200
WCB25	25 (1)	135	25	33	260	220
WCB32	32 (1.1/4)	135	32	33	260	250
WCB38	38 (1.1/2)	135	38	33	260	270
WCB51	51 (2)	135	51	33	260	320

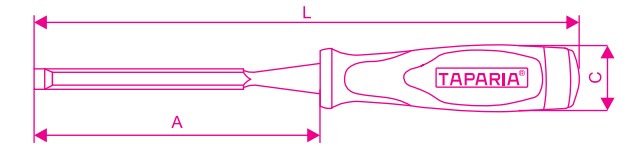

TAPARIA TOOLS LTD.



Head Office : 423 / 424, A-2, Shah & Nahar, Lower Parel (W), Mumbai - 400 013. Tel : 6147 8600
 Fax : 91-22-2495 3230. • E-mail : sales@tapariatools.com • Web Site : http://www.tapariatools.com
 Works : 52-B, M. I. D. C., Satpur, Nashik - 422 007. Tel : 2350 317 / 318 / 418 • Fax : 0253-2350740



An ISO-9001 Company

TAPARIA® TAPARIA® TAPARIA® TAPARIA® TAPARIA®



TAPARIA TOOLS LTD.

AN ISO - 9001 COMPANY



PINCERS



★ Made from high quality Steel, forged Heat treated and Black phosphated for long trouble free life. Cuts wires and pulls out nails with equal ease.

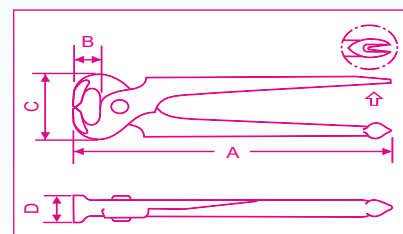

PROD. NO	A	B	C	D	WT. GMS
1541 - 8	200	23	49	21	350

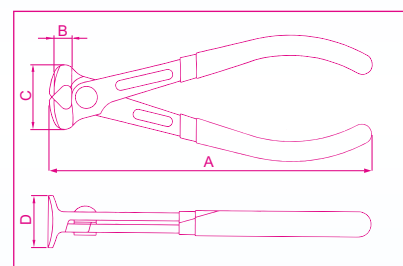

PROD. NO	A	B	C	D	WT. GMS
ECN 06	160	8	30	24	180

TOWER PINCERS



- * TAPARIA Tower Pincers are made from Cr-V Steel.
- * The cutting edges are differentially Hardened for long cutting life.
- * The long handles of these Tower Pincers are ergonomically designed for comfort in use.
- * Suitable for cutting wires and nails.

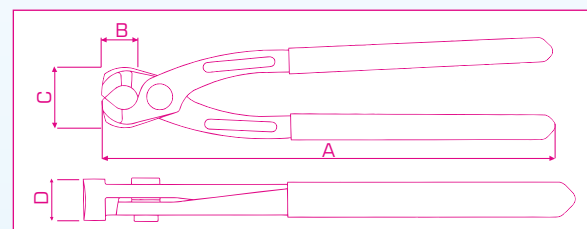

PROD. NO.	A	B	C	D	WT. GMS
TP 9	225	18	30	20	360

LOCKING PLIERS



- * Jaws are made high grade chrome vanadium steel.
- * Drop forged, fine finished with full hardening and tempering.
- * Provided with both straight and curved serration to hold different shapes easily.
- * Body made from good quality cold drawn steel sheets.
- * End screw is provided with knurling for quick jaw adjustment.
- * Smooth operating quick releasing mechanism help in single handed operation.
- * Provided with good quality and corrosive coating to prevent from rusting.

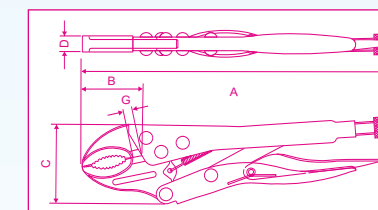

PRODUCT NO.	A	B	C	D	G	WEIGHT GRAMS
1641-5	125	30.0	44.0	9.0	5.0	160
1641-7	175	40.0	56.0	12.0	6.0	360
1641-10	250	45.0	65.0	12.0	6.0	540
1641-N	230	45.0	67.0	14.0	8.0	530
1642	250	-	65.0	12.0	-	540
1642-N	230	45.0	70.0	18.0	12.0	520
1643	230	42.0	68.0	12.0	7.0	490

LONG NOSE LOCKING PLIERS

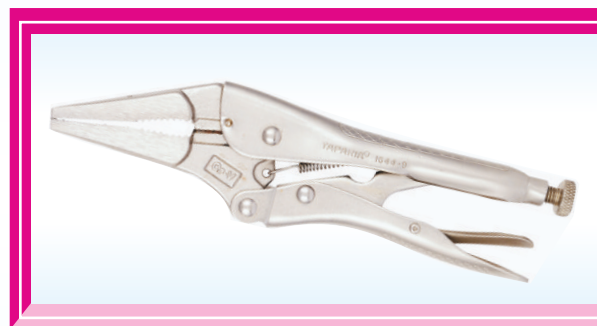

- * TAPARIA 9" Long Nose Locking Pliers are made from high grade alloy steel to enable higher force strength and longer life.
- * Differentially hardened teeth ensure good gripping and longer life.
- * Long nose provides access in narrow, and confined places.
- * It is ideal for precision jobs like tightening, clamping, twisting and turning.

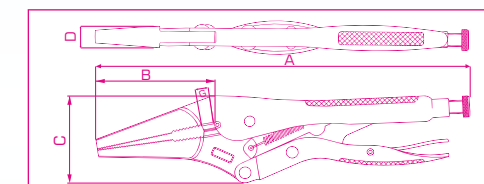

PRODUCT NO.	A	B	C	D	G	WEIGHT GRAMS
1644-9	216	68	56	12	12	375

LOCKING CLAMPS WITH SWIVEL PADS

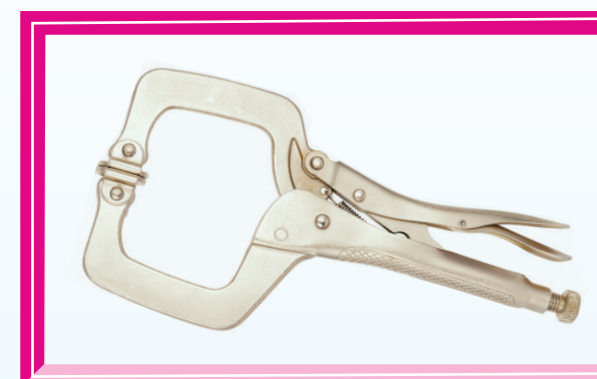

- * TAPARIA 11" Locking Clamps with Swivel Pads are made from high grade steel.
- * Precision heat treatment ensures higher force strength and longer life.
- * Wide opening jaws provide greater versatility for clamping a variety of shapes and sizes.
- * Swivel pads ensure proper clamping of tapered and delicate jobs without damaging the work surface.

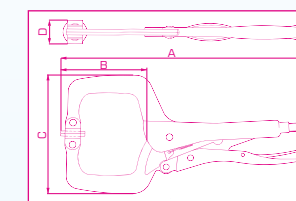

PROD. NO.	A	B	C	D	WT. GMS
1645 - 11	275	100	140	27	800

TAPARIA TOOLS LTD.

423 / 424, A-2, Shah & Nahar, Lower Parel (W), Mumbai - 400 013 (MH). ☎ : (022) 6147 8646.

E-mail : htaparia@tapariatools.com, sales@tapariatools.com • Web Site : <http://www.tapariatools.com>

Works : 52, M.I.D.C, Satpur, Nashik - 422 007 (MH), ☎ : (0253) 2350 317 / 18 / 418.

E-mail : nashik@tapariatools.com. C.I.N. No. : L99999MH1965PLC013392



TAPARIA® TAPARIA® TAPARIA® TAPARIA® TAPARIA®



TAPARIA TOOLS LTD.

AN ISO-9001 COMPANY



PIPE WRENCHES

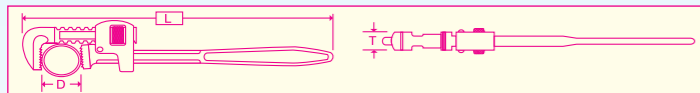

PROD. NO	D	T	L	WT. GMS
1272	33	15	250	500
1273	42	19	300	750
1274	48	21	350	1000
1275	60	24	450	1540
1276	73	28	600	2920
1277	90	34	900	5880

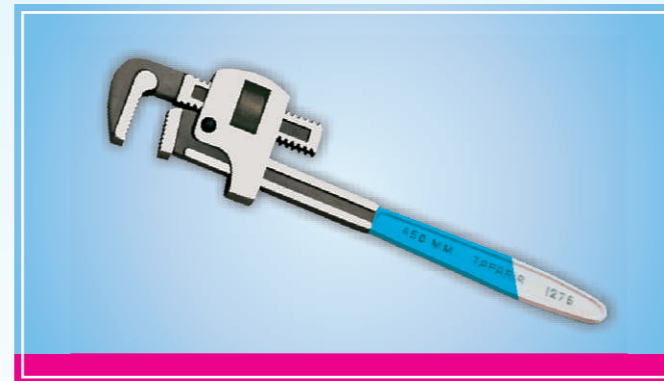

HEAVY DUTY UNIVERSAL PIPE WRENCHES

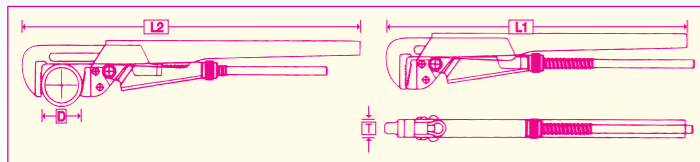

PROD. NO	A	B	C	D	WT. GMS
1510	38	17	275	310	690
2014	52	21	360	420	1244



HEAVY DUTY PIPE WRENCHES

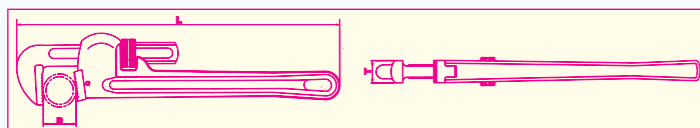

PROD. NO	NOM. PIPE	T	L	WT. GMS	PROD. NO	NOM. PIPE	T	L	WT. GMS
HPW 08	35	15	200	400	HPW 18	76	26	450	2400
HPW 10	49	17	250	850	HPW 24	90	33	600	4100
HPW 12	60	23	300	1100	HPW 36	140	37	900	8800
HPW 14	60	23	350	1650	HPW 48	166	37	1200	13800



ALUMINIUM PIPE WRENCH

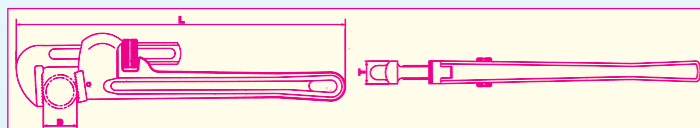

PROD. NO	NOM. PIPE	T	L	WT. GMS	PROD. NO	NOM. PIPE	T	L	WT. GMS
APW 10	49	17	250	600	APW 24	90	33	600	2500
APW 14	60	23	350	1000	APW 36	140	37	900	4750
APW 18	76	26	450	1500	APW 48	166	37	1200	7700



SPARES FOR HEAVY DUTY & ALUMINIUM PIPE WRENCH

PROD. NO	NOM. PIPE ØD	T	L	WT. GMS
HPW 12 S	60	23	300	1100
HPW 14 S	60	23	350	1650
HPW 18 S	76	26	450	2400

PROD. NO	NOM. PIPE ØD	T	L	WT. GMS
HPW 24 S	90	33	600	4100
HPW 36 S	140	37	900	8800
HPW 48 S	166	37	1200	13800

CHAIN PIPE WRENCHES

- Drop forged jaw from high grade steel
- Jaw teeth induction hardened for long life
- Jaw teeth provided on both sides for easy change of direction
- Accurately machined teeth provides firm and non-damaging grip.

PROD. NO	NOMINAL PIPE SIZE MAX ØD	L	L1	E	T	WT. GMS
CPW 04	CPW 04	900	165	80	12	8000
CPW 06	CPW 06	1000	180	90	13	9500
CPW 08	CPW 08	1200	190	90	14	11800
CPW 10	CPW 10	1300	215	95	15	13500
CPW 12	CPW 12	1400	215	95	15	14500
CPW 16	CPW 16	1585	215	95	15	16500

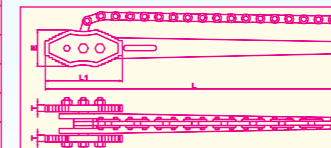

PIPE VICE

- Body made of malleable cast iron.
- Drop forged gripping jaws made from high grade steel.
- Heat treated and accurately machined jaw provides firm grip on pipes.

PROD. NO	NOM. PIPE SIZE ØA ØD	T	L	WT. GMS	
PV 00	10 - 40	16	95	60	1100
PV 01	10 - 60	24	145	105	4250
PV 02	10 - 90	24	190	105	5600
PV 03	15 - 115	24	215	120	7800
PV 04	15 - 165	30	260	160	10000

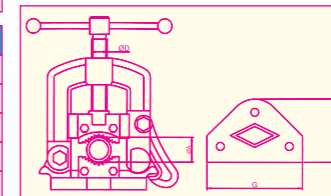

C-CLAMPS

- Body Hot drop forged from high grade steel.
- All parts fully heat treated and Black Phosphated for long trouble free service.
- Ideal for heavy duty application.

PROD. NO	A	B	C	D	WT. GMS
1259 - 2	200	55	49	22	360
1260 - 3	260	80	62	22	570
1261 - 4	330	105	75	25	1060
1263 - 6	440	155	93	25	1700
1264 - 8	565	205	106	32	2840

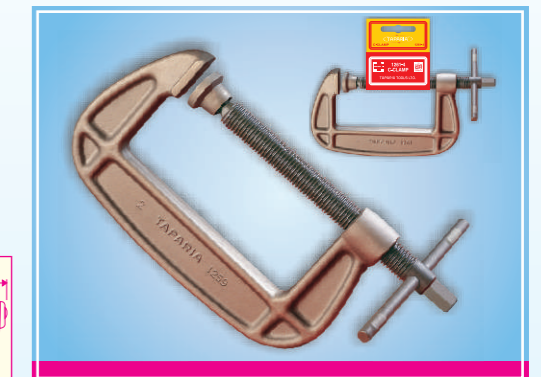
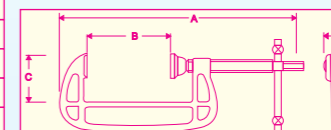

TAPARIA TOOLS LTD.



Head Office : 423 / 424, A-2, Shah & Nahar, Lower Parel (W), Mumbai - 400 013. & : 2493 8646 - 50
 Fax : 91-22-2495 3230. • E-mail : sales@tapariatools.com • Web Site : http://www.tapariatools.com
 Works : 52-B, M. I. D. C., Satpur, Nashik - 422 007. & : 2350 317 / 318 / 418 • Fax : 0253-2350740



An ISO-9001 Company

TAPARIA® TAPARIA® TAPARIA® TAPARIA® TAPARIA®



TAPARIA TOOLS LTD.

AN ISO-9001 COMPANY



Plastic Tool Box With Organizer

PLASTIC TOOL BOX WITH ORGANIZER

Product No.	H	W	L	Max. load carrying capacity including self weight (in kgs.)	Std. Pkg.
PTB 13	150	190	335	10	1
PTB 16	195	240	435	13	1
PTB 19	250	260	495	17	1
PTB 22	290	340	585	20	1



PTB 13



PTB 16



PTB 19



PTB 22

- ★ Metal rod hinges for higher load bearing capacity
- ★ Latch type locks for firm locking
- ★ Inside Tray for storing special tools.
- ★ Organizer sections on the top to store fasteners & small objects.
- ★ Specially designed handle for higher load carrying capacity.
- ★ Attractive looks and design.
- ★ Available in 420mm (16) & 480mm (19) sizes.



2 IN 1 ROLLING TOOL BOX SET

Contents :

- Top Tool Box (Size: 51 x 26 x 23 cm)
- Bottom Rolling Tool Box (Size: 61 x 37 x 37 cm)

Features :

- Strong rubber two Nos Strong Rubber Wheel of 150mm each.
- Top Box with a removable tray inside.
- Heavy duty steel latches.
- Pull out steel handle with cushion grip
- Built in V-groove with Metric scale.

61 x 37 x 37 cm

PTBR

2 IN 1 PLASTIC ROLLING TOOL BOX

Prod. No.	Description	Sizes	Std. Pkg.
PTBR	2 in 1 Rolling Tool Box Set	Top Box : 51x26x23 cm Bottom Box : 61x37x37 cm	1



Built in V-groove with Metric measuring increments



Pull out steel handle

TAPARIA TOOLS LTD.

Head Office : 423 / 424, A-2, Shah & Nahar, Lower Parel (W), Mumbai - 400 013. & : 6147 8600
 Fax : 91-22-2495 3230. • E-mail : sales@tapariatools.com • Web Site : http://www.tapariatools.com
 Works : 52-B, M. I. D. C., Satpur, Nashik - 422 007. & : 2350 317 / 318 / 418



AN ISO-9001 - 2015 COMPANY

TAPARIA® TAPARIA® TAPARIA® TAPARIA® TAPARIA®



TAPARIA TOOLS LTD.

AN ISO-9001 COMPANY



PLIERS



COMBINATION PLIERS

- ★ Made from high grade Steel, forged, and differentially heat treated to give best performance. Fully insulated with quality plastic material sleeves ensures safe electrical working.
- ★ Excellent wire cutting ability for soft and hard wires. Available with fully polished head or Black phosphated and bright polished head

PROD. NO	A	B	C	D	L	WT. GMS
1621 - 6	165	33	12	23.0	10.5	185
1621 - 7	185	33	12	23.0	11.5	240
1621 - 8	210	39	16	27.5	12.0	325
1611-6	165	35	13	25	10	170
1611-7	185	38	15	27	10.5	220
1611-8	200	40	17	30	12	285
1601-6	165	35	13	25	10	190
1601-7	185	38	15	27	10.5	220
1601-8	200	40	15	28	12	310

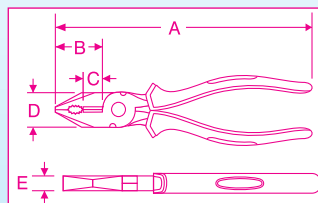

SIDE CUTTING PLIERS

★ Diagonal cutting edges, precision matched to optimum angle ensure long life for cutting hard and soft wires.

PROD. NO	A	B	C	D	WT. GMS
1121 - 6	165	21	18.5	10.5	165
Stripper 1122 - 6	165	21	18.5	10.5	165

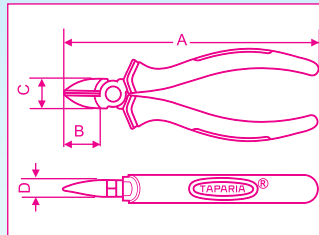

LONG NOSE PLIERS

★ Features accurately machined and heat treated jaws. Holds very thin wires and cuts fine wires with ease.

PROD. NO	A	B	C	D	E	F	WT. GMS
Flat Nose 1421 - 6	165	50	12	16	9	5.0	135
Long Nose 1430 - 6	170	50	12	16	9	2.0	135
Round Nose Plier 1431-6	165	50	-	16	9	2.5	130

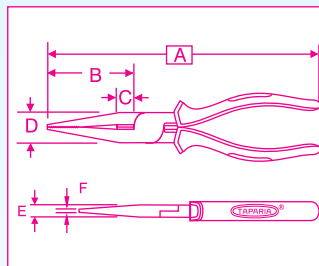

CIRCLIP PLIERS

★ Made from high quality Steel, forged Heat treated and Black phosphated for long trouble free life. Cuts wires and pulls out nails with equal ease.

PROD. NO	A	B	ØC	D	E	WT. GMS
STRAIGHT 1441 - 6	160	41	1.45	16	9	130
BENT 1442 - 6	145	28	1.45	16	9	130
STRAIGHT 1441 - 7	195	35	1.50	23	10	220
BENT 1442 - 7	180	24	1.50	23	10	220
STRAIGHT 1443 - 7	195	36	1.50	24	10	210
BENT 1444 - 7	180	25	1.50	24	10	210

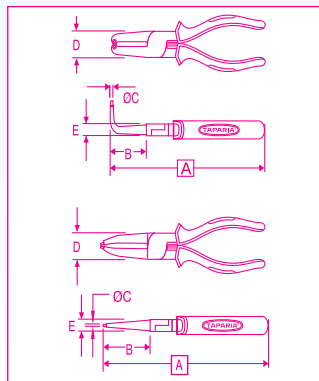

WATER PUMP PLIERS

★ Made out of high quality Steel, forged and accurately machined to hold circlips from 12 mm to 60 mm.

★ Correctly shaped jaws grips circlips without the danger of flying out. Available in straight and bent version.

PROD. NO	MAX. OPENING	A	C	L	WT. GMS
1220	Ø 35	35	8	200	180
1230	Ø 40	40	9	250	310
1223	Ø 35	35	10	200	250
1224	Ø 35	35	13	250	320
1225	Ø 45	45	13	250	400
1226	Ø 60	60	11	310	620

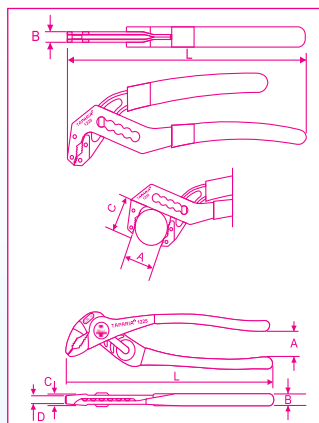

PINCER

★ Groove type locking design to provide strength and wear resistance. Diamond profile formed with combination of flat and serrations enables holding both round as well as flat surfaces firmly. Jaws design enables use in any position and in confined spaces.

PROD. NO	A	B	C	D	WT. GMS
1541 - 8	200	23	49	19	350
ECN 06	160	8	30	24	180

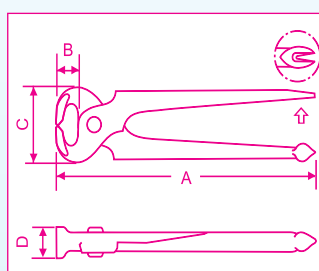

TAPARIA TOOLS LTD.



Head Office : 423 / 424, A-2, Shah & Nahar, Lower Parel (W), Mumbai - 400 013. & : 2493 8646 - 50
 Fax : 91-22-2495 3230. • E-mail : sales@tapariatools.com • Web Site : http://www.tapariatools.com
 Works : 52-B, M. I. D. C., Satpur, Nashik - 422 007. & : 2350 317 / 318 / 448 Fax : 0253-2350740



An ISO-9001 Company

TAPARIA® TAPARIA® TAPARIA® TAPARIA® TAPARIA®



TAPARIA TOOLS LTD.

AN ISO-9001 COMPANY



ECON PLIERS



H Economical range of Pliers with good quality.

H Drop Forged with quality Carbon steel.

H Accurately machined and heat treated.

H Improved aesthetics with two colour
Insulation Sleeves & smooth polish finish.

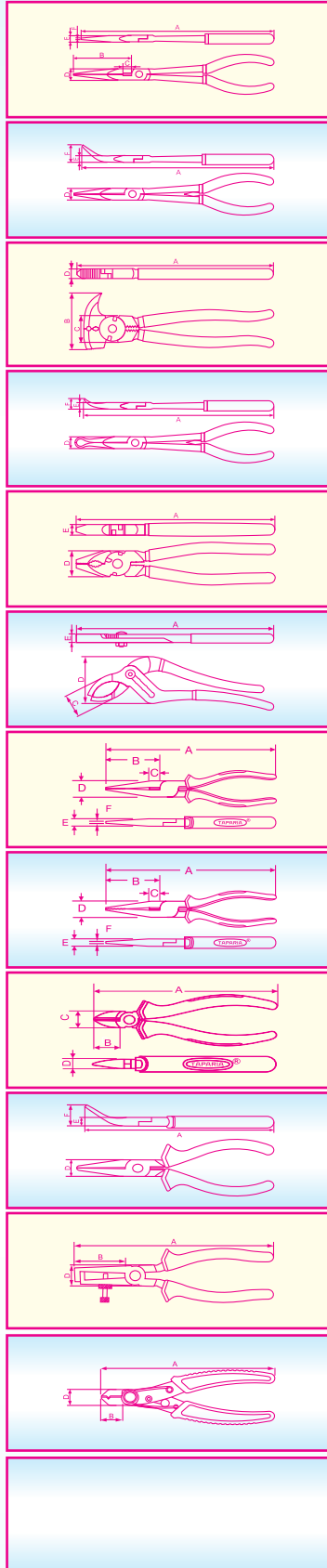
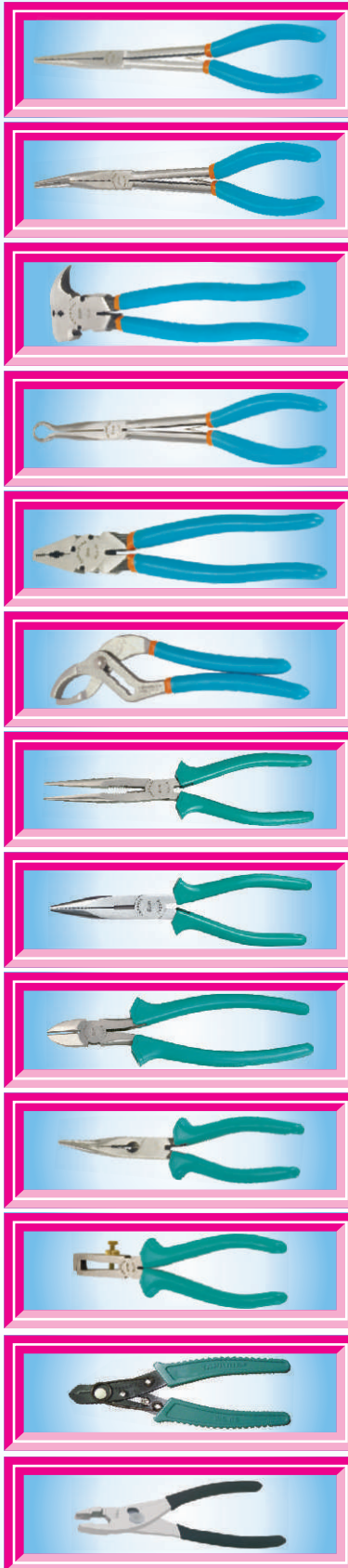

Long Nose Pliers

PROD. NO.	A	B	C	D	E	F	WT. GMS
LN 11	280	80	12.5	16.5	10	2.5	315

Bent Nose Pliers

PROD. NO.	A	D	E	F	WT. GMS
BN 11-45	270	17.5	10	32	310

Fencing Pliers

PROD. NO.	A	B	C	D	WT. GMS
FP 10	270	84	40	14	680

Long Reach Circle Nose Pliers

PROD. NO.	A	D	E	F	WT. GMS
LC 13 N 11	275	17.0	10	15	320

Multi Purpose Combination Pliers

PROD. NO.	A	D	E	WT. GMS
MCP 10	255	35	15	540
MCP 12	300	35	15	620

Drain Trap Pliers

PROD. NO.	A	C	E	D	WT. GMS
DTP 10	235	32	11	62	280

Econ Long Nose Pliers

PDCT NO.	A	B	C	D	E	F	WT. GMS
1420 - 8	215	75	13.5	17	9.0	2.5	180

Econ Long Nose Pliers

PROD. NO.	A	B	C	D	E	F	WT. GMS
1420-6	165	50	12.0	15.5	9	2.5	145

Econ Side Cutting Pliers

PROD. NO.	A	B	C	D	WT. GMS
1101 - 6	165	21	20	10.0	165
1101 - 8	205	27	23	11.5	275
HSC 7	190	25	25	12.5	280

Econ Bent Nose Pliers

PROD. NO.	A	D	E	F	WT. GMS
BN 06	170	16	9	20	145
BN 08	200	17	9	30	185

End Wire Stripping Pliers

PROD. NO.	A	B	D	E	WT. GMS
EWS 06	160	38	17	9	140

WIRE STRIPPER PLIERS

PROD. NO.	A	B	D	E	WT. GMS
WS 06	154	18	15	4	62

SLIP JOINT PLIERS

PROD. NO.	A	B	D	E	WT. GMS
1221	150	30	28	8.5	140

TAPARIA TOOLS LTD.



Head Office : 423 / 424, A-2, Shah & Nahar, Lower Parel (W), Mumbai - 400 013. & : 2493 8646 - 50
 Fax : 91-22-2495 3230. • E-mail : sales@tapariatools.com • Web Site : http://www.tapariatools.com
 Works : 52-B, M. I. D. C., Satpur, Nashik - 422 007. & : 2350 317 / 318 / 418 • Fax : 0253-2350740



An ISO-9001 Company

TAPARIA® TAPARIA® TAPARIA® TAPARIA®

PUNCHES



Made out of high grade Chrome Steel accurately machined and heat treated. Deep knurling on the Body ensures firm grip. Black phosphate finish.

Made out of high quality Chrome Steel, precision machined and heat treated to punch perfect holes in rubber, leather, carpet, etc. Black phosphate finish.

CENTRE PUNCH & DRIFT PUNCH

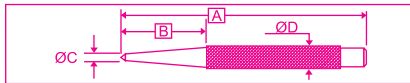

PROD. NO	A	B	Ø C	Ø D	WT. GMS
1884	100	26.5	3	8	35
1984	100	33	4	10	50
1985	125	40	5	12	80
1986	150	50	5	12	100
DRIFT PUNCH 1004	100	38	3	10	45

LEATHER PUNCHES

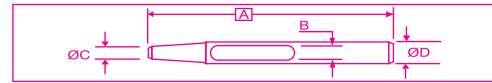

PROD. NO	A	B	Ø C	Ø D	WT. GMS
1786	100	6.5	7.0	12	60
1787	100	8.5	9.0	13	65
1788	100	10.5	11.5	14	70

DRIFT, CENTRE & LEATHER PUNCH SET

PROD. NO	CONTENTS
DCLP 7	1004, 1884, 1984, 1985, 1786, 1787, 1788

PIN PUNCH SET

PROD. NO	LENGTH	CONTENTS
PPI 6	100 mm.	PP24, PP32, PP40, PP48, PP55, PP63
PPI 4	150 mm.	PP40L, PP48L, PP55L, PP63L

PIN PUNCHES

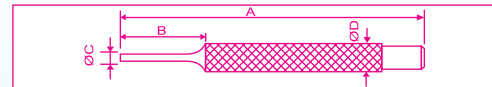

PROD. NO	A	B	Ø C	Ø D	WT. GMS
PP 24	100	35	2.4	10	39
PP 32	100	35	3.2	10	40
PP 40	100	35	4.0	10	41
PP 48	100	35	4.8	10	42
PP 55	100	35	5.5	10	44
PP 63	100	35	6.3	10	46
PP 40 L	150	75	4.0	10	51
PP 48 L	150	75	4.8	10	55
PP 55 L	150	75	5.5	10	58
PP 63 L	150	75	6.3	10	62
PP 80 L	150	75	8.0	12	90
PP 100 L	150	75	10.0	12	108

TAPARIA TOOLS LTD.



Head Office : 423 / 424, A-2, Shah & Nahar, Lower Parel (W), Mumbai - 400 013. & : 2493 8646 - 50
Fax : 91-22-2495 3230. • E-mail : sales@tapariatools.com • Web Site : http://www.tapariatools.com
Works : 52-B, M. I. D. C., Satpur, Nashik - 422 007. & : 2350 317 / 318 / 418 • Fax : 0253-2350740



An ISO-9001 Company

TAPARIA® TAPARIA® TAPARIA® TAPARIA® TAPARIA®



TAPARIA TOOLS LTD.

AN ISO-9001 COMPANY



SCREW DRIVER BITS



80 PCS S/D BIT SET

- ★ 80 pcs screw driver Bit Set is an ideal buy for workshops, garages, assembly lines in factory and all professionals.
- ★ The Bit Set contains variety of Screw Driver Bits, Adaptors and a Ratchet Bit Driver.
- ★ The Screw Driver Bits in the set are Nickel Chrome Plated.

PROD. NO.	CONTENTS
BS 80 (WEIGHT GRAMS 1325)	25 mm Hex - 2, 2.5, 3, 4, 5, 6
	25 mm Flat - 3, 4, 5, 5.5, 6, 6.5
	25 mm Torx - T8, T10, T15, T20, T25, T27, T30, T40 (without Tamper / without Hole)
	25 mm Torx - TT8, TT10, TT15, TT20, TT25, TT27, TT30, TT40 (with Tamper / with Hole)
	25 mm Phillips - PH0, PH1, PH2, PH3
	25 mm Adaptor - (1/4 Sq. Drive)
	50 mm Hex - 2, 2.5, 3, 4, 5, 6
	50 mm Flat - 3, 4, 5, 5.5, 6, 6.5
	50 mm Torx - T8, T10, T15, T20, T25, T27, T30, T40 (without Tamper / without Hole)
	50 mm Torx - TT8, TT10, TT15, TT20, TT25, TT27, TT30, TT40 (with Tamper / with Hole)
	50 mm Phillips - PH0, PH1, PH2, PH3
	50 mm Adaptor - (1/4 Sq. Drive)
	65 mm Two-in-One- PH1xSL4.5, PH2xSL5.5, PH3xSL6.5, PH1xPH1, PH1xPH2, PH2xPH2, PH2xPH3, PH3xPH3
	110 mm Two-in-One- PH1xPH1, PH2xPH2, PH3xPH3
	60 mm Bit Holder, Ratchet Bit Driver

BIT DRIVER SET WITH S/D BITS

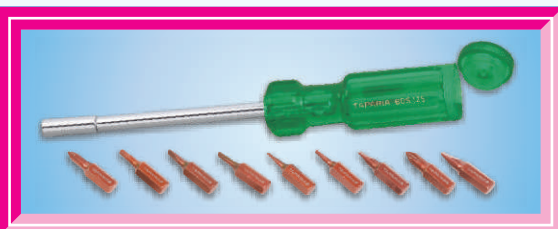

- ★ A portable & Economical Bit Set for all professionals and householders.
- ★ Ten most commonly used Screw Drive Bits of 25 mm length placed in-side the handle of a sturdy Bit Driver.

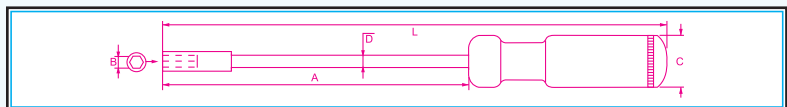

PROD. NO.	A	B	C	D	L	CONTENTS	WT. GMS
BDS 125	125	6.40	31	8	242	Torx - T5, T6, T8, T10 Phillips No. 0, 1, 2 Flat : 3mm, 4mm, 5mm	130

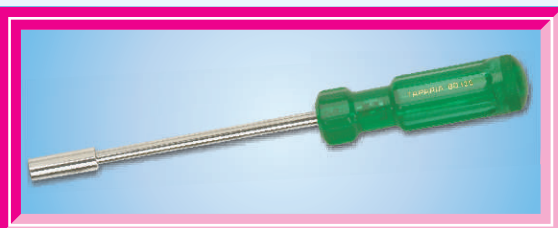

BIT DRIVER

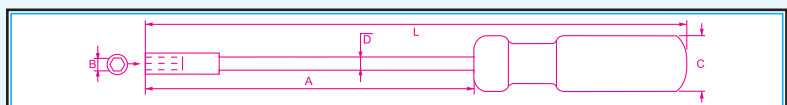

PROD. NO.	A	B	C	D	L	WT. GMS
BD 125	125	6.40	26	6	222	90

**SCREW DRIVER BITS -
(1/4) HEXAGONAL DRIVE :**

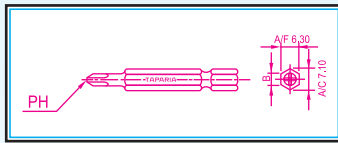
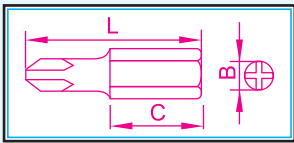

- ★ Made from expensive high alloy steel.
- ★ Accurately hardened & Tempered to 56-60 HRC.
- ★ To withstand high torque and high wear resistance properties.
- ★ Precisely machined Phillips, Torx, Flat & Hexagon Tips.
- ★ One of the widest range of quality Screw Driver Bits in india.

PHILLIPS HEAD SCREW DRIVER BITS

25MM & 50 MM SINGLE HEAD

PROD. NO.	SIZE	B	C	L	WT. GMS
SBP 250	0	4	15	25	5.0
SBP 251	1	5	15	25	5.0
SBP 252	2	6	15	25	5.0
SBP 253	3	6	15	25	5.0
SBP 500	0	4	25	50	8.0
SBP 501	1	5	40	50	11.0
SBP 502	2	6	40	50	11.0
SBP 503	3	6	25	50	11.0

50MM, 65MM & 110 MM DOUBLE HEAD



PROD. NO.	SIZE	PH A	B1	B2	L	WT. GMS
SBPP 5011	50xPH1xPH1	1 1	5	5	50	10.0
SBPP 5012	50xPH1xPH2	1 2	5	6	50	10.0
SBPP 5013	50xPH1xPH3	1 3	5	6	50	10.0
SBPP 5022	50xPH2xPH2	2 2	6	6	50	11.0
SBPP 5023	50xPH2xPH3	2 3	6	6	50	11.0
SBPP 5033	50xPH3xPH3	3 3	6	6	50	11.0
SBPP 6512	65xPH1xPH2	1 2	6.35	6.35	65	14.0
SBPP 6523	65xPH2xPH3	2 3	6.35	6.35	65	14.0
SBPP 11011	110xPH1xPH1	1 1	5	5	110	25.0
SBPP 11012	110xPH1xPH2	1 2	5	6	110	25.0
SBPP 11022	110xPH2xPH2	2 2	6	6	110	25.0
SBPP 11023	110xPH2xPH3	2 3	6	6	110	25.0
SBPP 11033	110xPH3xPH3	3 3	6	6	110	25.0

TORX HEAD SCREW DRIVER BITS

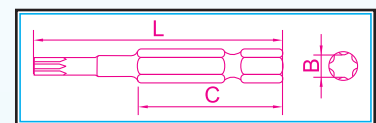
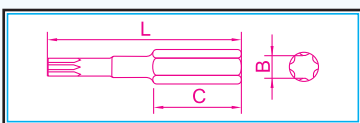

25 MM SINGLE HEAD

PROD. NO.	SIZE	C	L	WT. GMS
SBT 255	T 5	11	25	4.0
SBT 256	T 6	11	25	4.0
SBT 257	T 7	11	25	4.0
SBT 258	T 8	11	25	4.0
SBT 259	T 9	11	25	4.0
SBT 2510	T 10	11	25	4.5
SBT 2515	T 15	11	25	4.5
SBT 2520	T 20	11	25	4.5
SBT 2525	T 25	11	25	5.0
SBT 2527	T 27	11	25	5.0
SBT 2530	T 30	11	25	5.0
SBT 2540	T 40	-	25	5.5
SBT 2545	T 45	11	25	6.0



50 MM SINGLE HEAD

PROD. NO.	SIZE	C	L	WT. GMS
SBT 505	T 5	11	50	7.0
SBT 506	T 6	11	50	7.0
SBT 507	T 7	11	50	7.0
SBT 508	T 8	11	50	7.0
SBT 509	T 9	11	50	7.0
SBT 5010	T 10	11	50	7.5
SBT 5015	T 15	11	50	7.5
SBT 5020	T 20	11	50	8.0
SBT 5025	T 25	11	50	9.0
SBT 5027	T 27	11	50	10.0
SBT 5030	T 30	11	50	11.0
SBT 5040	T 40	-	50	12.0

FLAT HEAD BITS

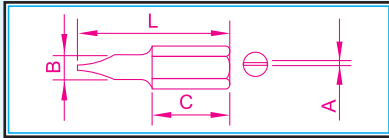

25 MM

PROD. NO.	SIZE	A	B	C	L	WT. GMS
SBF 253	25x3x0.5	0.50	3	15	25	4.5
SBF 254	25x4x0.6	0.60	4	15	25	4.5
SBF 255	25x5x0.8	0.80	5	15	25	5.0
SBF 256	25x6x1.0	1.00	6	15	25	5.0
SBF 258	25x8x1.2	1.20	8	15	25	5.0

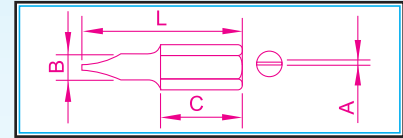

50 MM

PROD. NO.	SIZE	A	B	C	L	WT. GMS
SBF 503	50x3x0.5	0.50	3	25	50	8.5
SBF 504	50x4x0.6	0.60	4	25	50	8.5
SBF 505	50x5x0.8	0.80	5	25	50	10.0
SBF 506	50x6x1.0	1.00	6	25	50	11.0
SBF 508	50x8x1.2	1.20	8	25	50	11.0

HEXAGON HEAD BITS

METRIC SERIES 25 MM & 50 MM LENGTH

PROD. NO.	B	C	L	WT. GMS
SBH 2515	1.5	17	25	4.0
SBH 252	2	17	25	4.0
SBH 2525	2.5	17	25	4.5
SBH 253	3	17	25	5.0
SBH 254	4	17	25	5.0
SBH 255	5	17	25	6.0
SBH 256	6	17	25	6.0
SBH 258	8	17	25	8.0
SBH 2510	10	17	25	10.0
SBH 5015	1.5	40	50	10.0
SBH 502	2	40	50	10.0
SBH 5025	2.5	40	50	10.0
SBH 503	3	25	50	11.0
SBH 504	4	40	50	11.0
SBH 505	5	40	50	12.0
SBH 506	6	40	50	12.0
SBH 508	8.0	9.20	50	21.0
SBH 5010	10.0	11.50	50	33.0

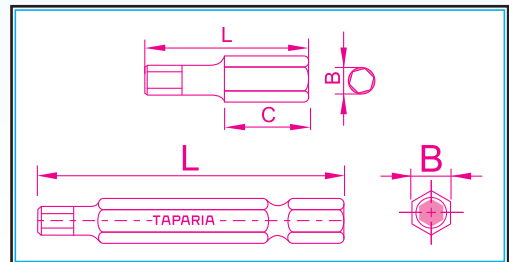

INCH SERIES 50 MM LENGTH

PROD. NO.	B	C	L	WT. GMS
SBH 50116	1/16	40	50	10.0
SBH 50564	5/64	40	50	10.0
SBH 50332	3/32	40	50	10.0
SBH 50764	7/64	40	50	10.0
SBH 5018	1/18	40	50	11.0
SBH 50964	9/64	40	50	11.0
SBH 50532	5/32	40	50	11.0
SBH 50316	3/16	40	50	12.0
SBH 50732	7/32	40	50	12.0
SBH 5014	1/4	40	50	12.0

TWO IN ONE SCREW DRIVER BITS

50 MM, 65 MM & 110 MM

PROD. NO.	PH	A	B	B1	L	WT. GMS
SBPF 5026	2	1.0	6	6	50	10.0
SBPF 65145	1	1.0	4.5	6.35	65	14.0
SBPF 65255	2	1.0	5.5	6.35	65	14.0
SBPF 65365	3	1.0	6.5	6.35	65	14.0
SBPF 11026	2	1.0	6	6	110	25.0





TAPARIA TOOLS LTD.

AN ISO-9001 COMPANY



SCREW DRIVERS



★ **TAPARIA**® Offer the most comprehensive range of screw drivers, made out of High Grade Steel and Transparent green cellulose acetate handle.

★ The handle is made from high grade C A Plastic which is non flammable and unaffected by oil, petrol, grease, water etc.

★ Available in wide variety of different tip size & length.

★ Available in Engineer's, Electrician's with insulation on full length of blade, Phillips, and Pozi drive Pattern. Also available with Black tip for superior performance.

★ The handle is precisely designed to give comfortable grip even at higher torque.

★ Hardness on the tip :- 55 - 58 H. R. C.

SCREW DRIVERS (ENGINEER'S)

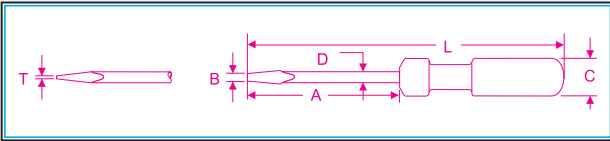

PROD. NO	TIP SIZE B x T	A	C	D	L	WT. GMS
932	0.6 x 0.4	50	13	3	110	10
933	1.6 x 0.4	75	13	3	135	12
911	3.0 x 0.4	50	13	3	110	10
901	3.0 x 0.5	75	17	3	150	21

902	3.0 x 0.4	100	17	3	175	22
912	3.5 x 0.5	75	14	3.5	140	16
913	4.0 x 0.6	100	18	4	180	30

712	4.0 x 0.6	125	17	4	200	30
713	5.0 x 0.6	75	18	5	155	35
921	6.0 x 0.6	75	22	6	161	55
922	6.0 x 0.6	100	22	6	186	60

923	6.0 x 0.8	125	22	6	211	62
824	6.0 x 0.8	150	22	6	236	65
825	6.0 x 0.8	200	22	6	286	77
826	6.0 x 0.8	250	22	6.0	336	90

924	8.0 x 1.2	125	28	8.0	230	115
925	8.0 x 1.2	150	28	8.0	255	130
926	8.0 x 1.2	175	28	8.0	280	130
827	8.0 x 1.2	200	28	8.0	305	145

828	8.0 x 1.2	250	28	8.0	355	165
829	8.0 x 1.2	300	28	8.0	405	180
725	8.0 x 1.2	150	26	8.0	248	120
927	10.0 x 1.2	200	34	10.0	327	245

928	10.0 x 1.2	250	34	10.0	377	275
929	10.0 x 1.5	300	34	10.0	427	310
930	10.0 x 1.5	400	34	10.0	527	365
931	13.0 x 1.9	450	34	10.0	577	395

SCREW DRIVERS (ELECTRICIAN'S)

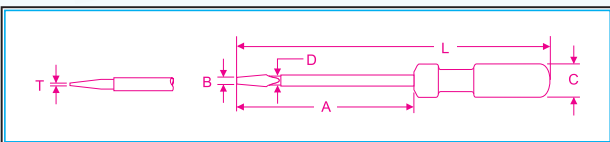

PROD. NO	TIP SIZE B x T	A	C	D	L	WT. GMS
822	3.5 x 0.5	125	17	3.5	200	30
842	3.5 x 0.5	150	17	3.5	225	35
832	3.5 x 0.5	200	17	3.5	275	40

823	4.0 x 0.6	150	18	4.0	230	40
833	4.0 x 0.6	200	18	4.0	280	40
934	5.0 x 0.6	100	22	5.0	186	50
935	5.0 x 0.6	125	22	5.0	211	55

936	5.0 x 0.8	150	22	5.0	236	60
937	5.0 x 0.8	200	22	5.0	286	70
938	5.0 x 0.8	250	22	5.0	336	80
939	5.0 x 0.8	300	22	5.0	386	90

SCREW DRIVERS (PHILLIPS)

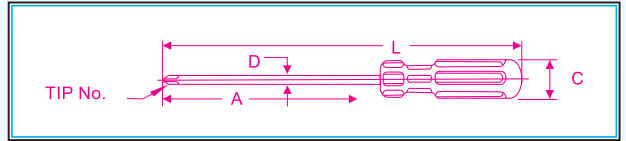

PROD. NO	TIP SIZE B x T	A	C	D	L	WT. GMS
P2 859 50	00	50	13	3	108	15
P3 860 60	0	60	17	3	135	20
P3 860 150	0	150	17	3	225	25
P5 861 75	1	75	22	3	160	50

P5 861 100	1	100	22	5	185	55
P5 861 150	1	150	22	5	235	60
P5 861 200	1	200	22	5	285	65
P6 862 100	2	100	22	6	198	80

P6 862 150	2	150	26	6	248	95
P6 862 200	2	200	26	6	298	110
P6 862 250	2	250	26	6	348	125
P6 862 300	2	300	26	6	398	140

P8 863 150	3	150	28	8	255	155
P8 863 200	3	200	28	8	305	175
P8 863 250	3	250	28	8	355	195
P8 863 300	3	300	28	8	405	215
P1 864 200	4	200	34	10	327	250

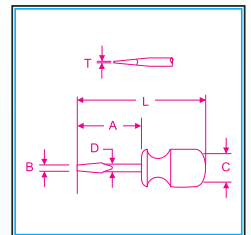

PROD. NO	TIP SIZE B x T	A	C	D	L	WT. GMS
954	6.0 x 0.8	25	30	6	75	40
964	6.0 x 0.8	50	30	6	100	45
966	9.0 x 1.2	50	30	8	100	60
855	6.0 x PHILLIPS NO.2	50	30	6	100	45

TWO IN ONE STUBBY SCREW DRIVER

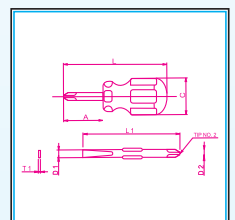

PROD. NO	A	C	D	L	TIP SIZE D1 x T1	TIP SIZE D2 x T2	L1	WT. GMS
974	95	22	6	180	6.0 x 0.8	6.0 x 2 PHILLIPS	75	55

SCREW DRIVERS TWO-IN-ONE

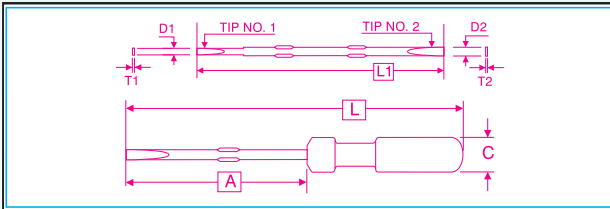

PROD. NO.	A	C	L	TIP SIZE D1 x T1	TIP SIZE D2 x T2	L1	WT. GMS
803	55	17	130	3.5 x 0.5	3.5 x 0 PHILLIPS	122	25
804	75	18	155	5.0 x 0.8	5.0 x 1 PHILLIPS	122	40
809	75	18	155	5.0 x 0.8	3.5 x 0.5	127	40
810	60	14	125	2.3 x 0.4	2.5 x 00 PHILLIPS	110	20
850	200	22	284	3.5 x 0 PHILLIPS	5.0 x 1 PHILLIPS	250	80
851	200	25	396	5.0 x 1 PHILLIPS	6.0 x 2 PHILLIPS	250	105
852	200	27	313	6.0 x 2 PHILLIPS	8.0 x 3 PHILLIPS	255	170
903	250	23	342	6.0 x 0.8	2.5 x 00 PHILLIPS	300	100
904	100	23	192	6.0 x 0.7	5.0 x 1 PHILLIPS	150	60
905	140	23	232	6.0 x 0.8	6.0 x 2 PHILLIPS	190	70
906	140	27	245	8.0 x 0.9	8.0 x 3 PHILLIPS	205	115

STRIKING SCREW DRIVER



PROD. NO	A	C	D	L	WT. GMS
OGS 8210	75	17	3.0	140	22
OGS 8260	150	17	3.0	215	28
OGS 1200	75	17	3.0	150	22
OGS 1250	150	17	3.0	225	28

SCREW DRIVER WITH CA GREEN WITH BIGGER SIZE HANDLES

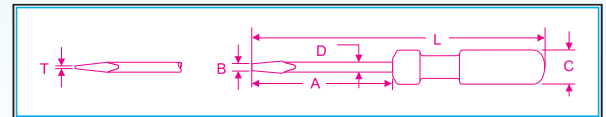

PROD. NO	TIP SIZE B x T	A	C	D	L	WT. GMS
922 H5	6.0 x 0.6	100	26	6	198	75
923 H5	6.0 x 0.6	125	26	6	223	80
824 H5	6.0 x 0.6	150	26	6	248	90
825 H5	6.0 x 0.6	200	26	6	298	100
826 H5	6.0 x 0.6	250	26	6	348	110
839 H5	6.0 x 0.6	300	26	5	398	120

TORX SCREW DRIVERS

★ The blade is made from high grade silicon manganese steel.

★ The blade is fully hardened & tempered withstand high torque requirements.

★ The blade is magnetized to lift screws etc from confined spaces or to hold screw in position.

★ The blade is effectively protected against corrosion by Nickel Chrome plating.

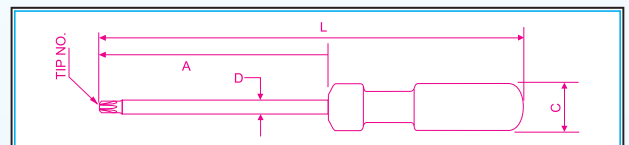
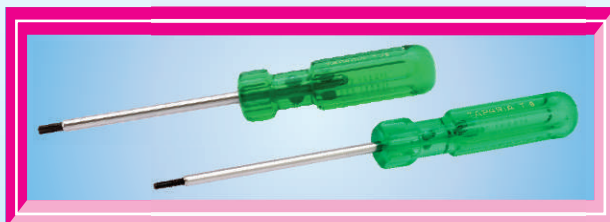

PROD. NO	A	C	D	L	WT. GMS
T - 5	75	17	3.0	140	22
T - 5L	150	17	3.0	215	28
T - 6	75	17	3.0	150	22
T - 6L	150	17	3.0	225	28
T - 8	75	17	3.5	150	25
T - 8L	150	17	3.5	225	35
T - 10	75	17	3.5	150	25
T - 10L	150	17	3.5	225	35
T - 15	75	22	5.0	161	50
T - 15L	150	22	5.0	236	60
T - 20	100	22	5.0	186	55
T - 20L	200	22	5.0	286	65
T - 25	100	26	6.0	198	90
T - 25L	200	26	6.0	298	105
T - 30	100	26	6.0	198	90
T - 30L	200	26	6.0	298	105
T - 40	125	28	8.0	230	120
T - 40L	200	28	8.0	305	150

SCREW DRIVERS (POKER)

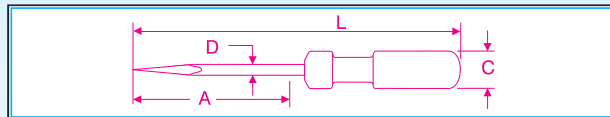
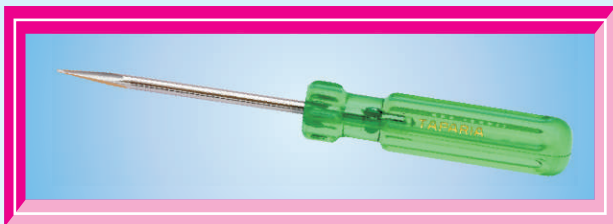

PROD. NO	TIP SIZE B X T	A	C	D	L	WT. GMS
871	SQ. POKER	95	22	6	180	55

SCREW DRIVERS SETS

PROD. NO	NO. OFF BLADES	COLLET TYPE	A	C	D	L	BLADE TIP SIZES	WT. GMS
821	6	STEEL COLLET	75	22	6	175	Phillips No.00; Phillips No.0; 6.0x0.6; Phillips No.1;	210
848	4	CLIP TYPE	77	25	6	175	Phillips No.2; Phillips No.3 2.5x0.4, 3.5x0.5, 5x0.6, 6x0.6 Phillips No.00, 0, 1.	175



SCREW DRIVERS SETS (SPECIAL WITH NEON BULBS)



PROD. NO	NO. OFF BLADES	COLLET TYPE	A	C	D	L	BLADE TIP SIZES	WT. GMS
802	5	CLIP TYPE	95	18	6	175	6.0x0.8; 3.5x0.5; Phillips No. 0; Square Poker; Phillips No. 1	145
812	5	STEEL COLLET	95	25	6	200	6.0x0.8; 3.5x0.5; Phillips No. 0; Square Poker; Phillips No. 1	170
820	8	CLIP TYPE	9	18	5	175	6.0x0.8; 4.3x0.6; 3.5x0.5; Sq.Poker; Phillips No.1; Phillips No.2 Round Poker; Wood Screw Type. 6.0x0.8; 4.3x0.6; 3.5x0.5; Sq.Poker;	180
831	8	CLIP TYPE	95	22	5	190	Phillips No.1; Phillips No.2 Round Poker; Wood Screw Type.	190
840	6	STEEL COLLET	95	25	6	200	6.0x0.8; 3.5x0.5; Phillips No.0; Extension Bar, Square Poker; Phillips No.1	185
891	5	CLIP TYPE	60	18	3.5	135	3.5x0.5; 2.5x0.4; 1.6x0.4; Square Poker; Phillips No. 00	50

SCREW DRIVERS KITS (HANGING POUCH)

PROD. NO	CONTENT
1012	Consisting of 6 Screw Drivers 827, 913, P5 861 75, 824, 913, 713
1013	Consisting of 8 Screw Driver 713, 922, 725, 828, 912, 712, 937, p5 861 75



SCREW DRIVERS KITS (BLISTER PACKING)

PROD. NO	CONTENT
1014	Consisting of 7 Screw Drivers 824, P5 861 75, P6 862 100, 913, 925, 935, 814
1017	Consisting of 5 Phillips Screw Driver P3 859 50, P3 860 60, P5 861 75, P6 862 100, P8 863 200



LINE TESTER

- ★ **TAPARIA®** Line Tester has high quality blade and cellulose acetate plastic Handle.
- ★ Fully insulated blade ensures shock proof working.
- ★ Distinct glow of Neow lamp identifies line 'live'.
- ★ Features a clip for safe carrying in pocket.
- ★ Available in several sizes.

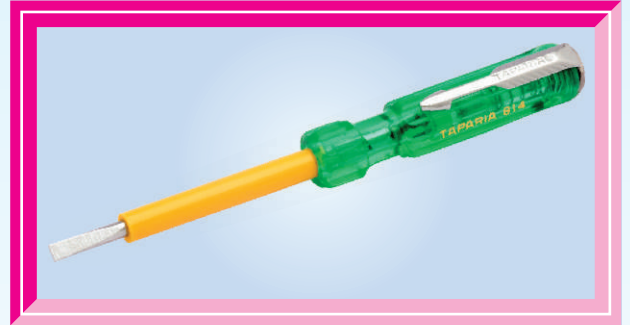

SCREW DRIVERS (SPECIAL WITH NEON BULBS)

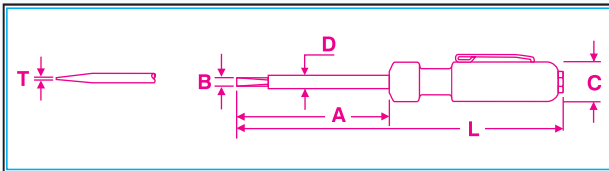

PROD. NO	A	TIP SIZE B x T	C	D	L	WEIGHT GRAMS
813	55	3.5 x 0.4	17	6	130	25
814	60	3.5 x 0.5	14	6	125	20
815	100	3.5 x 0.5	18	6	180	35

816	95	3.5 x 0.5	17	6	170	35
818	60	SQ. POKER	14	6	125	20
873	114	4.0 x 0.6	18	4	200	30

THREE IN ONE TESTER



- ★ Consists of a **TAPARIA®** Line Tester and an easily attachable extension cord with a Test Probe.
- ★ Easily checks 'live' or Neutral wire, continuity or break in circuit.
- ★ Identifies two different phases.
- ★ Ideal for domestic use.

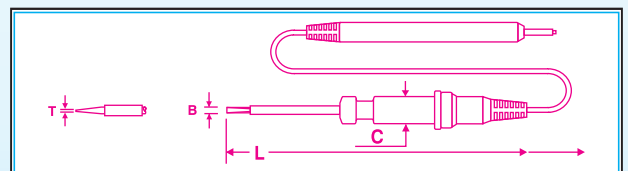

PROD. NO	TIP SIZE B x T	C	L	WEIGHT GRAMS
817 - 1413	3.5 x 0.5	14	1200	65

MULTIPURPOSE DIGITAL TESTER (MDT 81)

★ **TAPARIA®** Multipurpose Digital Testers are useful for a wide variety of electrical functions as follows :-

- 1) To Measure 12V to 220V AC and DC Voltage.
- 2) To locate break point of an insulated wire.
- 3) To check flow of current in an insulated wire from outside.

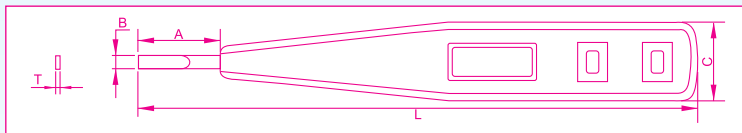

PROD. NO.	A	B x T	C	L	WT. GMS
MDT 81	20	3.0 x 0.5	18	130	17
MDT N 82	20	3.0 x 0.5	18	130	17

TIPS for use :-

1) For measuring voltage

- a) The extreme right displayed voltage is the voltage of the wire tested, whether it is 12V, 36V, 55V, 110V, 220V. As shown in fig. ①
- b) The Digital tester will display full voltage value e.g. 220 when atleast 70% of 220 voltage is measured or else it will show the lower step voltage i.e. 110V.
- c) To check DC voltage touch upper button of the tester.
- d) To check below 12 volts touch induction button as in fig. ②

2) To check continuity or break point of a wire.

- a) For checking the Phase line and Neutral line, place the tester blade on the PVC insulation of the wire. Only in case of Phase line flash mark will appear on the LCD Display as shown in fig. ② in the above drawing.
- b) To check continuity on parallel lines, it is necessary to separate them from each other, so as to eliminate interference.
- c) Break point can be detected by touching the outside of PVC insulation of the wire. The exact break point will be at the place where ↘ flash mark stops glowing as shown in case of fig. ③

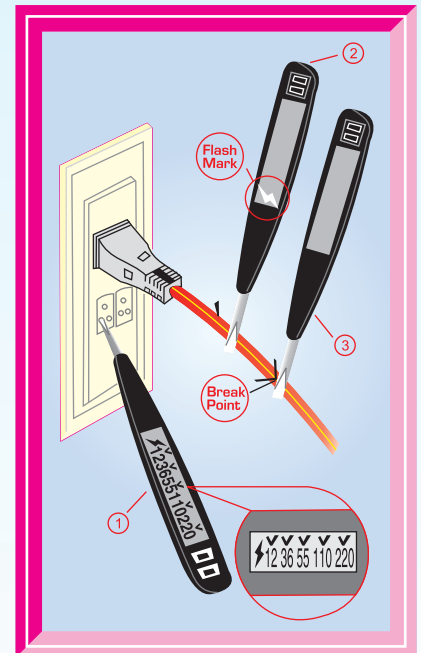

TAPARIA TOOLS LTD.



Head Office : 423 / 424, A-2, Shah & Nahar, Lower Parel (W), Mumbai - 400 013. & : 2493 8646 - 50
Fax : 91-22-2495 3230. • E-mail : sales@tapariatools.com • Web Site : http://www.tapariatools.com
Works : 52-B, M. I. D. C., Satpur, Nashik - 422 007. & : 2350 317 / 318 / 418 • Fax : 0253-2350740



An ISO-9001 Company

TAPARIA® TAPARIA® TAPARIA® TAPARIA®



TAPARIA TOOLS LTD.

AN ISO-9001 COMPANY



SNAP OFF CUTTERS



Prod.No.	Blade Width mm	Std. Pkg.
SK-1	19	10 Pcs.



- ABS plastic body for higher strength metal — to hold the blade firmly during use.
- Blade made from high grade steel for sharp and long cutting.
- Ergonomically shaped body with soft grip for comfort in use.
- Locking system for enhanced safety.

Prod.No.	Blade Width mm	Std. Pkg.
SKE-9	9	
SKE-18	18	



Prod.No.	Blade Width mm	Std. Pkg.
SKB-9	9	
SKB-1810	18	

- Blade made from high grade steel for sharp & long cutting.
- Auto locking system for safety & ease in operation
- Ergonomically designed body

UTILITY KNIFE



- TAPARIA Utility Knife is made from Die Cast Zinc for higher strength.
- Blades made from high grade steel for sharp and long cutting.
- Two extra spare blades provided inside the body.
- Ergonomically shaped body for comfort in cutting.

Prod.No.	Blade Width mm	Std. Pkg.
UK-3	19	6 Pcs.



- SPARE BLADE FOR (UK-3)

Prod.No.	Blade Width mm	Std. Pkg.
UB-10	19	10 Pcs.

TAPARIA TOOLS LTD.



Head Office : 423 / 424, A-2, Shah & Nahar, Lower Parel (W), Mumbai - 400 013. Tel : 6147 8600
 Fax : 91-22-2495 3230. • E-mail : sales@tapariatools.com • Web Site : http://www.tapariatools.com
 Works : 52-B, M. I. D. C., Satpur, Nashik - 422 007. Tel : 2350 317 / 318 / 418 • Fax : 0253-2350740



An ISO-9001 Company

TAPARIA® TAPARIA® TAPARIA® TAPARIA® TAPARIA®



TAPARIA TOOLS LTD.

AN ISO-9001 COMPANY



SOCKET SET

SOCKET SET 12.7 MM (1/2") SQUARE DRIVE REGULAR & EXEL

Consists of Selected Sockets and Accessories, neatly packed in attractive powder coated carrying case.



PRODUCT NO.				CONTENTS
REGULAR		EXEL		
Bihexagonal Socket sets	Hexagonal Socket sets	Bihexagonal Socket sets	Hexagonal Socket sets	
S-11 M (MM)	S-11 H (MM)	S-11 M/XL	S-11 HXL	10, 11, 12, 13, 14, 15, 16, 17, 18, 19, 21, 22, 23, 24, 26, 27, 28, 29, 30, 32, 33 & 34
(22 Sockets + 5 Accessories)		(22 Sockets + 5 Accessories)		Accessories - Reversible Ratchet 1715
				Extension Bar 1753, Extension Bar 1763, Universal Joint 1773, T-Handle 1733,
S-14 M (MM)	S-14 H (MM)	S-14 MXL	S-14 HXL	8, 9, 10, 11, 12, 13, 14, 15, 16, 17, 18, 19, 21, 22, 23, 24, 26, 27, 28, 29, 30 & 32
(22 Sockets + 5 Accessories)		(22 Sockets + 5 Accessories)		Accessories - Reversible Ratchet 1715
				Extension Bar 1753, Extension Bar 1763, Universal Joint 1773, T-Handle 1733,
S-15 M (MM)	S-15 H (MM)	S-15 MXL	S-15 HXL	11, 12, 13, 14, 15, 16, 17, 18, 19, 21, 22, 23, 24, 26, 27, 28, 29, 30 & 32
(19 Sockets + 5 Accessories)		(19 Sockets + 5 Accessories)		Accessories - 1753, 1763, 1773, 1733, 1715, 1783,
S-16 M (MM)	S-16 M (MM)	S-16 MXL	S-16 HXL	11, 12, 13, 14, 15, 16, 17, 18, 19, 21, 22, 23, 24, 26, 27, 28, 29, 30 & 32
(19 Sockets + 6 Accessories)		(19 Sockets + 6 Accessories)		Accessories - 1753, 1763, 1773, 1733, 1715, 1783, Handle 1734
S-22 M (MM)	S-22 H (MM)	S-22 HXL	S-22 HXL	10, 11, 13, 14, 17, 19, 22, 24, 27, 30 & 32
(11 Sockets + 4 Accessories)		(11 Sockets + 4 Accessories)		Accessories - Ext.Bar 1753, Ext.Bar 1763, Flexible Handle 1703, Reversible Ratchet 1715
S-23 M (MM)	S-23 M (MM)	S-23 MXL	S-23 HXL	8, 9, 10, 11, 12, 13, 14, 15, 16, 17, 18, 19, 21 & 22
(14 Sockets + 4 Accessories)		(14 Sockets + 4 Accessories)		Accessories - Ext.Bar 1753, Ext.Bar 1763, Offset Handle 1734, T-Handle 1733S
				S-31 MXL S-31 HXL 11, 14, 17, 19, 22 & 24
				(6 Sockets + 1 Accessory) Angle Handle 1734

SOCKETS

Hot upset forged high grade chrome vanadium steel to ensure highest quality. Available with 12.7 mm (1/2") square drive with 12 cornered Bihexagonal Pattern and 6 cornered Hexagonal Pattern for Impact application. Also available with 19mm (3/4) square drive with 12 cornered Bihexagonal pattern.

Thoroughly corrosion protected with Bright Nickel Chrome finish Heat treated to give torque ratings far above prescribed ratings.

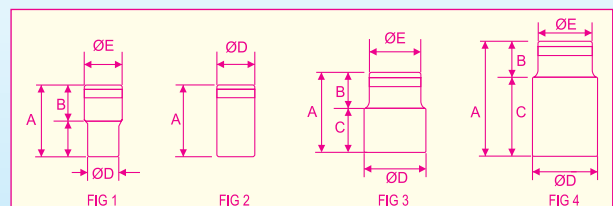



1/2 DRIVE BIHEXAGONAL AND HEXAGONAL SOCKETS

PROD. NO	FIG NO.	A	B	C	ØD	ØE	A/F	WEIGHT GRAMS
8	1	36	20	16	12.0	22	8	45
9	1	36	20	16	13.0	22	9	45
10	1	36	20	16	16.0	22	10	45

11	1	36	20	16	17.5	22	11	48
12	1	36	20	16	18.7	22	12	50
13	1	36	20	16	20.0	22	13	52
14	1	36	20	16	21.3	22	14	52

15	2	38	-	-	22.5	-	15	52
16	2	38	-	-	23.5	-	16	52
17	2	38	-	-	25.0	-	17	75
18	2	38	-	-	25.5	-	18	70

19	2	40	-	-	27.5	-	19	90
21	2	40	-	-	28.9	-	21	104
22	2	40	-	-	31.0	-	22	125
23	2	43	-	-	31.3	-	23	120

24	3	43	18	25	32.5	30	24	130
26	3	43	18	25	35.2	30	26	140
27	3	46	18	25	36.4	30	27	150
28	3	46	18	28	37.7	30	28	165

29	3	46	18	28	38.9	30	29	165
30	3	46	18	28	40.4	30	30	185
32	3	46	17	29	42.7	30	32	195
33	3	46	17	29	43.9	30	33	195
34	3	46	17	29	45.2	30	34	190

Heavy Duty Hexagonal SOCKETS

PROD. NO	FIG NO.	A	B	C	ØD	ØE	A/F	WEIGHT GRAMS
HD 10	1	36	20	16	17.0	22.5	10	55
HD 11	1	36	20	16	18.5	22.5	11	60
HD 13	1	38	21	17	21.2	24.0	13	80

HD 14	1	38	21	17	22.5	24.0	14	80
HD 17	2	38	-	-	26.5	-	17	85
HD 19	2	38	-	-	29.3	-	19	120
HD 22	2	38	-	-	33.3	-	22	170

LD 18	2	80	-	-	26.5	-	18	165
LD 24	4	80	25	55	34.3	31.5	24	280
EL 10	-	150	18	15	16.0	23.0	10	174

SOCKETS 12.7 mm (1/2") SQUARE DRIVE

PROD. NO	FIG NO.	A	B	C	ØD	ØE	A/F	WEIGHT GRAMS
SP 16	1	36	20	16	14.0	22.5	8	55
SP 21	1	36	20	16	15.0	22.5	9	50

EXEL SOCKETS - 12.7 MM (1/2") SQUARE DRIVE

PROD. NO	FIG NO.	A	B	C	ØD	ØE	A/F	WEIGHT GRAMS
FD 8	1	36	20	16.5	13.5	22	8	50
FD 9	1	36	20	16.5	14.5	22	9	50
FD 10	1	36	20	16.5	15.7	22	10	50
FD 11	1	38	21.5	16.5	16.7	22	11	50

FD 12	1	38	21.5	16.5	17.8	22	12	50
FD 13	1	38	21.5	16.5	19.0	22	13	50
FD 14	1	38	21.5	16.5	20.2	22	14	50
FD 15	1	38	21.5	16.5	21.0	22	15	50

FD 16	3	38	16	22	21.8	20.5	16	50
FD 17	3	38	16	22	23.8	22	17	60
FD 18	3	38	16	22	25.8	22	18	80
FD 19	3	38	16	22	25.8	22	19	70

FD 20	3	38	16	22	27.8	25	20	80
FD 21	3	38	16	22	28.0	25	21	70
FD 22	3	38	16	22	29.8	26	22	90
FD 23	3	38	16	22	31.8	28	23	115
FD 24	3	38	16	22	31.8	28	24	105

FD 25	3	40	17	23	33.7	30	25	125
FD 26	3	42	17	25	35.5	31	26	158
FD 27	3	42	17	25	35.8	32	27	158
FD 28	3	44	17	27	37.6	33	28	188

FD 29	3	44	17	27	38.0	33	29	180
FD 30	3	44	16	28	39.5	34	30	200
FD 32	3	44	16	28	41.5	36	32	225

IMPACT SOCKET - HEXAGONAL 12.7 MM (1/2") SQ. DRIVE

PROD. NO	FIG NO.	A	B	C	ØD	ØE	A/F	WEIGHT GRAMS
IM 8	1	36	21	15	13.5	25	8	60
IM 9	1	36	21	15	14.5	25	9	65
IM 10	1	36	21	15	17	25	10	65
IM 11	1	38	21	15	18.5	25	11	65

IM 12	1	36	21	15	20	25	12	65
IM 13	1	36	21	15	21.5	25	13	75
IM 14	1	36	21	15	22.5	25	14	70
IM 15	1	36	21	15	24.0	25	15	80

IM 16	2	38	21	15	25.0	25	16	80
IM 17	2	38	21	15	26.5	26.5	17	95
IM 18	2	38	21	15	28.0	28	18	105
IM 19	2	38	21	15	30.0	30	19	120

IM 20	3	40	17	23	31.0	30	20	80
IM 21	3	40	17	23	32.0	30	21	95
IM 22	3	40	17	23	33.5	30	22	105
IM 23	3	40	18	25	35.0	30	23	120

IM 24	3	43	18	25	36.0	30	24	170
IM 26	3	43	18	25	38.9	30	26	175
IM 27	3	43	18	25	40.0	30	27	180
IM 28	3	46	19	27	41.5	30	28	200

IM 29	3	46	19	27	42.5	30	29	215
IM 30	3	46	19	27	44.0	30	30	220
IM 31	3	46	19	27	44.5	30	31	225
IM 32	3	46	19	27	46.5	30	32	245

DEEP SOCKETS 1/2" SQUARE DRIVE

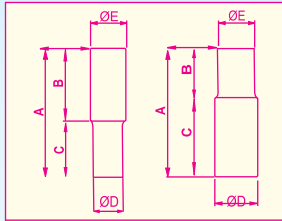

PROD. NO	FIG NO.	A	B	C	ØD	ØE	A/F	WEIGHT GRAMS
L8H	1	76	42	34	14	22	8	110
L10H	1	76	42	34	16	22	10	110
L11H	1	76	42	34	17	22	11	110
L12H	1	76	42	34	18	22	12	110

L13H	1	76	42	34	19	22	13	115
L14H	1	76	42	34	20.5	22	14	120
L15H	3	76	30	46	22	22	15	120
L16H	3	76	30	46	22	22	16	110

L17H	3	76	30	46	24	22	17	130
L18H	3	76	30	46	26	24	18	160
L19H	3	76	30	46	26	24	19	150
L20H	3	76	30	46	28	25	20	175

L21H	3	76	30	46	28	25	21	165
L22H	3	76	30	46	30	26	22	195
L24H	3	76	30	46	32	28	24	215
L27H	3	76	30	46	36	32	27	280
L30H	3	76	30	46	40	28	34	350

SOCKET SET (3/4" SQUARE DRIVE)

PROD. NO		CONTENTS
Bihexagonal Socket sets	Hexagonal Socket sets	
S-3/4 BH	S-3/4 H	22, 24, 27, 30, 32, 36, 38, 41, 46, & 50
[10 Sockets + 4 Accessories]		Accessories : Extension Bar 2753, Extension Bar 2763, T-Handle 2733, Ratchet Handle with Coupler 2715.



3/4 SQ. DRIVE SOCKETS

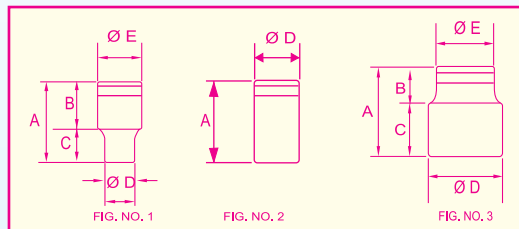

PROD. NO	FIG NO.	A	B	C	ØD	ØE	A/F	WEIGHT GRAMS
C 19	1	50	28	22	29.0	36	19	200
C 21	1	50	28	22	31.0	36	19	200
C 22	1	50	30	20	33.0	36	22	215
C 24	1	50	30	20	35.0	36	24	210

C 26	3	52	22	30	36.0	35	26	215
C 27	2	51.5	-	-	38.0	-	27	220
C 28	3	52	21	31	40.0	36	28	235
C 29	3	52	21	31	40.0	38	29	240

C 30	3	54	21	33	42.0	38	30	265
C 32	3	56	21	35	44.0	38	32	300
C 33	3	56	23	33	46.0	38	33	315
C 34	3	58	22	36	46.0	38	34	320

C 35	3	58	22	36	48.0	42	35	380
C 36	3	58	20	38	50.0	42	36	395
C 38	3	60	20	40	52.0	45	38	450
C 41	3	64	24	40	56.0	45	41	535

C 42	3	64	22	42	58.0	45	42	590
C 46	3	68	21	47	62.0	48	246	685
C 50	3	72	24	48	68.0	48	50	800
C 55	3	76	26	48	74.0	48	55	955

C 60	3	78	30	48	78.0	48	60	910
C 65	3	85	30	55	86.0	48	65	1570
C 70	3	85	30	55	91.0	48	70	1680



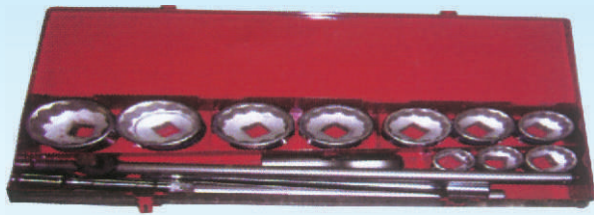

BI-HEXAGONAL SOCKET SET (1" SQUARE DRIVE)

PROD. NO.	CONTENTS
S1BH	Socket ; 36 mm, 41 mm, 46 mm, 50 mm, 55 mm,
(10 Sockets &	60mm, 65 mm, 70 mm, 75 mm & 80 mm
4 Accessories)	Accessories - 3715, 3733, 3753, 3763

SOCKET 1" SQ. DRIVE

PROD. NO.	FIG NO.	A	B	C	ØD	ØE	A/F	WT. GMS
D 36	3	60	20	40	50	46	36	400
D 38	3	65	22	43	54	46	38	520
D 41	3	65	25	40	54	46	46	520

D 46	3	75	26	49	65	50	46	830
D 50	3	75	26	49	69	56	50	1050
D 55	3	80	28	52	75	56	55	1200
D 60	3	84	30	54	81	56	60	1350

D 65	3	88	30	58	87	56	65	1550
D 70	3	94	30	64	93	68	70	2100
D 75	3	98	34	64	99	68	75	2500
D 80	3	103	34	69	105	68	80	2600

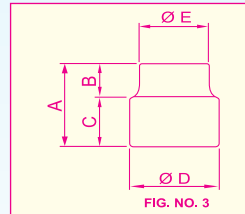

SOCKET SET

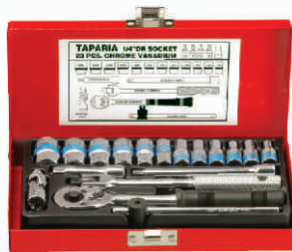

Consists of selected sockets and accessories, neatly packed in attractive powder coated carrying case.

SOCKET SET 1/4 SQ. DRIVE

PROD. NO.	CONTENTS
S 1/4 H	Sockets - 4, 4.5, 5, 5.5, 6, 7, 8, 10, 11, 12, 13, 14.
(17 Sockets +	Adaptor - Hex 1/4 x SQ. 1/4
6 Accessories)	Adaptor Torx - T20, T 25, T30, T40
	Accessories - A 733 - T- Handle, A 743 - Extn.Bar,
	A 753 - Extn.Bar, A 773 - Universal Joint,
	A 703 - Nut spinner Flexible, A 715 - Ratchet Handle

SOCKET 1/4 SQ. DRIVE

PROD. NO	FIG NO.	A	B	C	ØD	ØE	A/F	WT. GMS
A 4 H	1	25	13	12	6.8	12	4	10
A 4.5 H	1	25	13	12	7.3	12	4.5	10
A 5 H	1	25	13	12	8.0	12	5	10
A 5.5 H	1	25	13	12	8.5	12	5.5	10
A 6 H	1	25	13	12	9.0	12	6	10
A 7 H	1	25	13	12	10.5	12	7	10
A 8 H	1	25	13	12	11.7	11	8	10
A 10 H	3	25	11	14	14	12	10	10
A 11 H	3	25	11	14	16	14	11	20
A 12 H	3	25	11	14	17	15	12	20
A 13 H	3	25	11	14	18	16	13	25

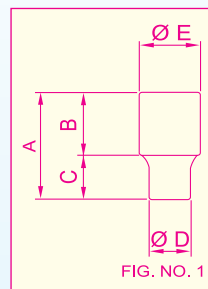

SOCKET SET 3/8 SQ. DRIVE

PROD. NO.	CONTENTS
S 3/8 H	Sockets - 6, 7, 8, 9, 10, 11, 12, 13, 14, 17, 19, 21, 22
(14 Sockets +	Spark Plug Socket - BSP 21
6 Accessories)	Accessories - B 733 - T- Handle, B 743 - Extn.Bar,
	B 753 - Extn.Bar, B 773 - Universal Joint,
	B 703 - Nut spinner Flexible, B 715 - Ratchet Handle

SOCKET 3/8 SQ. DRIVE

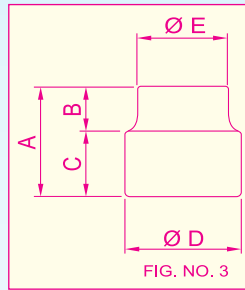

PROD. NO	FIG. NO.	A	B	C	ØD	ØE	A/F	WEIGHT GRAMS	STD. PKG.
B 6 H	1	28	16	12	10.3	17	6	25	5
B 7 H	1	28	16	12	11	17	7	25	5

B 8 H	1	28	16	12	12	17	8	25	5
B 9 H	1	28	16	12	13.3	17	9	25	5
B 10 H	1	28	16	12	14.5	17	10	25	5

B 11 H	3	28	16	12	16	17	11	25	5
B 12 H	3	28	12	16	17	15.5	12	25	5
B 13 H	3	28	12	16	17.8	16.5	13	25	5
B 14 H	3	28	12	16	19.7	17	14	25	5

B 17 H	3	30	12	18	23.7	20	17	45	5
B 19 H	3	30	12	18	26	23	19	60	5
B 21 H	3	30	12	18	28	25	21	70	5
B 22 H	3	30	12	18	29.7	26	22	80	5

SOCKET ACCESSORIES

T-HANDLE

SIZE	PROD. NO.	A/F	L	ØD	ØE	ØF	WT. GMS
1/4 Drive	A 733	6.30	115	14	8.0	6.0	45
3/8 Drive	B 733	9.50	200	19	12.6	10.5	75
1/2 Drive	1733-S	12.7	250	27	16.6	13	345
3/8 Drive	1733	12.7	300	27	16.6	13	400
3/4 Drive	2733	19	500	38	24.5	18	1220
1 Drive	3733	25	630	49	33.8	25	2970

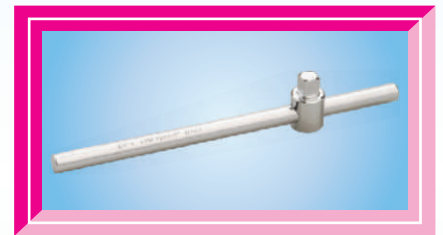
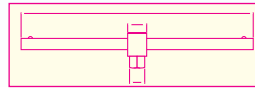

EXTENSION BAR

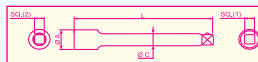

SIZE	PROD. NO.	L	ØA	ØB	ØD	SQ.(1)	SQ.(2)	WT. GMS
1/4 Drive	A 743	50	12	-	8.0	6.40	6.30	25
	A 753	100	12	-	8.0	6.40	6.30	45
3/8 Drive	B 743	76	18	-	12.0	9.60	9.50	75
	B 753	152	18	-	12.0	9.60	9.50	140

1/2 Drive	1713	50	22	-	12.8	12.8	12.8	85
	1743	75	22	-	12.8	12.8	12.8	110
	1753	125	22	-	12.8	12.8	12.8	150
	1763	255	22	-	12.8	12.8	12.8	290

3/4 Drive	2753	255	35	-	19.1	19.1	19.1	700
	2763	385	35	-	19.1	19.1	19.1	980
1 Drive	3753	20	48	-	29.0	25.2	25.8	1320
	3763	400	48	-	29.0	25.2	25.8	2410

RATCHET HANDLE

R-HANDLE	PROD. NO.	FIG. NO.	A	B	L	WT. GMS
1/4 Drive	A 715	1	12	27	160	135
3/8 Drive	B 715	1	13	27	215	340
1/2 Drive	1715	2	18	35	255	480
	1715 N	2	16	46	260	550
3/4 Drive	2715 With Sq. Coupler	-	30	65	500	2040
1" Drive	3715 R-H	1	32	69	-	-
	T-BAR	2	Ø28	-	562	2680

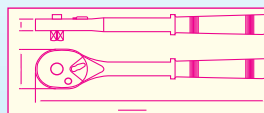

FLEXIBLE HANDLE

SIZE	PROD. NO.	FIG NO.	A	B	L	WT. GMS
1/4 Drive	A 703	2	11	16.5	145	115
3/8 Drive	B 703	2	15	22	225	215
1/2 Drive	1703	1	20	25	250	390

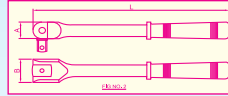

UNIVERSAL JOINT

SIZE	PRODUCT NO	FIG NO.	A	B	L	WEIGHT GRAMS
1/4 Drive	A 773	3	14	14	39	25
3/8 Drive	B 773	3	19	19	55	65
1/2 Drive	1773	3	25	22	74	160
3/4 Drive	2273	3	40	40	108	560

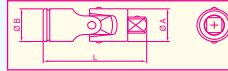

ANGLE HANDLE

PROD. NO.	L1	L2	ØA	ØB	SQ	WEIGHT GRAMS
1734/1734N	189	56	---	16	12.7	320
1735	250	60	---	16	12.7	430
1736	300	75	---	16	12.7	525
1737	450	120	---	16	12.7	835

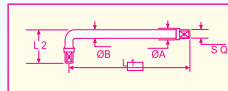

SPEEDER BRACE

PROD. NO.	ØD1	ØD2	L	L1	SQ	WEIGHT GRAMS
1783	13	22	397	146	12.7	760

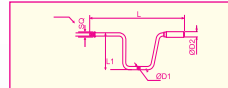

3/4 - SQUARE DRIVE

PROD. NO.	SQ	L	WEIGHT GRAMS
2716	19.5	52	150

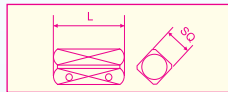

TAPARIA TOOLS LTD.



Head Office : 423 / 424, A-2, Shah & Nahar, Lower Parel (W), Mumbai - 400 013. & : 2493 8646 - 50
 Fax : 91-22-2495 3230. • E-mail : sales@tapariatools.com • Web Site : http://www.tapariatools.com
 Works : 52-B, M. I. D. C., Satpur, Nashik - 422 007. & : 2350 317 / 318 / 418 • Fax : 0253-2350740



An ISO-9001 Company

TAPARIA® TAPARIA® TAPARIA® TAPARIA® TAPARIA®



TAPARIA TOOLS LTD.

AN ISO-9001 COMPANY



SPANNERS



DOUBLE ENDED SPANNERS

- ★ Made from high grade Steel.
- Forged and accurately machined.
- Hardened and tempered to give long trouble free service.
- Provide with appropriate surface protection for rust prevention.

RING SPANNERS

- ★ Made from high grade Steel.
- ★ Forged and accurately machined.
- ★ Hardened and tempered to give long trouble free service.
- ★ Provide with appropriate surface protection for rust prevention.

DOUBLE ENDED SPANNER SET (WITH RIB)

PROD. NO	CONTENTS
DER 06	6x7, 8x9, 10x11, 12x13, 14x15, 16x17
DER 08	6x7, 8x9, 10x11, 12x13, 14x15, 16x17, 18x19, 20x22
DER 10	6x7, 8x9, 10x11, 12x13, 14x15, 16x17, 18x19, 20x22, 21x23, 24x27
DER 12	6x7, 8x9, 10x11, 12x13, 14x15, 16x17, 18x19, 20x22, 21x23, 24x27, 25x28, 30x32
DER 010	6x7, 8x9, 10x11, 12x13, 14x15, 16x17, 18x19, 20x22, 24x27, 30x32

DOUBLE ENDED SPANNER SET (WITHOUT RIB)

PROD. NO	CONTENTS
DER 06	6x7, 8x9, 10x11, 12x13, 14x15, 16x17
DER 08	6x7, 8x9, 10x11, 12x13, 14x15, 16x17, 18x19, 20x22
DER 10	6x7, 8x9, 10x11, 12x13, 14x15, 16x17, 18x19, 20x22, 21x23, 24x27
DER 12	6x7, 8x9, 10x11, 12x13, 14x15, 16x17, 18x19, 20x22, 21x23, 24x27, 25x28, 30x32
DER 010	6x7, 8x9, 10x11, 12x13, 14x15, 16x17, 18x19, 20x22, 24x27, 30x32

DOUBLE ENDED SPANNER (WITH RIB)

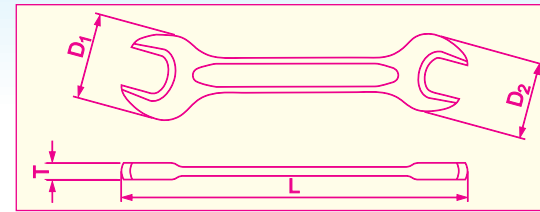

PROD. NO	D 1	D 2	T	L	WT. GMS
DER - 6 x 7	15.5	17.5	4.0	95	15
DER - 8 x 9	19.0	22.0	5.0	105	30
DER -10 x 11	23.0	25.0	6.0	120	40
DER -12 x 13	27.5	30.5	6.5	130	55
DER -14 x 15	32.0	34.0	7.0	150	75
DER -16 x 17	36.0	39.0	7.0	160	95
DER -18 x 19	40.0	42.0	7.5	175	120
DER -20 x 22	44.0	49.0	8.0	195	180
DER -21 x 23	45.0	49.0	8.0	215	205
DER -24 x 27	51.0	59.0	8.0	235	260
DER -25 x 28	55.0	62.0	9.0	255	325
DER -30 x 32	66.0	70.0	10.0	280	465
DER - 32 x 36	66.0	73.0	11.5	300	525
DER - 36 x 41	—	—	—	—	—
DER - 41 x 46	83.0	94.0	13.0	375	870
DER - 46 x 50	—	—	—	—	—

DOUBLE ENDED SPANNER (WITHOUT RIB)

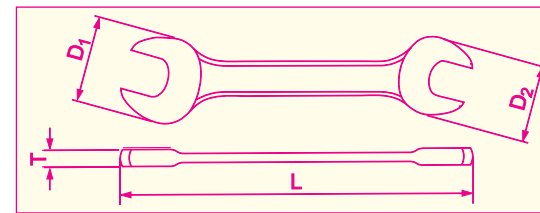

PROD. NO	D 1	D 2	T	L	WT. GMS
DEP - 06 x 07	14.0	16.0	3.0	95	10
DEP - 08 x 09	17.5	19.0	3.5	100	20
DEP - 10 x 11	22.0	23.0	4.0	110	30
DEP - 12 x 13	25.5	27.5	5.0	125	40
DEP - 14 x 15	29.0	31.0	5.5	145	60
DEP - 16 x 17	33.0	36.0	5.5	160	75
DEP - 18 x 19	37.5	40.0	6.5	180	115
DEP - 20 x 22	40.0	43.5	7.0	200	140
DEP - 21 x 23	41.0	45.0	7.0	210	155
DEP - 24 x 27	48.5	53.5	7.5	225	215
DEP - 25 x 28	49.0	54.5	8.0	225	235
DEP - 30 x 32	58.0	62.5	8.5	250	320
DEP - 08 x 10	17.0	21.5	4.0	115	28
DEP - 09 x 11	21.5	24.0	5.0	120	38
DEP - 10 x 12	25.5	27.0	5.5	130	38
DEP - 13 x 16	27.0	33.0	6.0	170	75
DEP - 14 x 17	30.0	35.0	6.0	160	82
DEP - 18 x 21	37.0	42.0	7.0	180	120
DEP - 19 x 22	40.0	45.0	7.5	200	150

SINGLE END OPEN JAW SPANNER

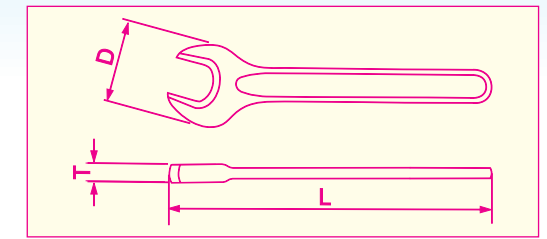

PROD. NO	S	D	T	L	WT. GMS
SER 24	-24	-50	8.0	210	145
SER 30	30	62	10.0	260	290
SER 32	32	65	10.0	275	290
SER 36	36	72	11.0	300	400
SER 38	38	77	11.5	300	425
SER 41	41	83	12.5	340	425
SER 46	46	91	13.0	375	520
SER 50	50	101	15.0	400	920
SER 55	55	111	15.0	440	1150
SER 60	60	122	16.0	475	1375
SER 65	65	132	16.0	515	1640
SER 70	70	140	17.0	555	2000
SER 75	75	151	18.0	585	2220

DOUBLE ENDED RING SPANNER

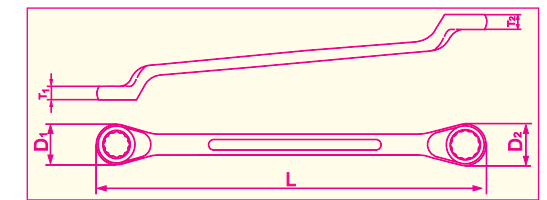

PROD. NO	D1	D2	T1	T2	L	WT. GMS
18 - 6 x 7	11.0	12.5	5.0	6.0	180	40
18 - 8 x 9	14.0	16.5	6.0	7.0	190	50
18 - 10 x 11	17.0	18.0	7.0	8.0	200	75
18 - 12 x 13	19.0	21.0	8.0	8.5	215	95
18 - 14 x 15	22.0	24.0	8.5	10.0	230	105
18 - 16 x 17	25.0	26.5	10.0	10.5	245	160
18 - 18 x 19	28.0	29.0	11.0	11.0	260	210
18 - 20 x 22	31.0	33.0	12.0	13.0	290	270
18 - 21 x 23	31.5	34.0	13.0	13.5	310	290
18 - 24 x 27	37.0	41.0	13.0	14.0	340	390
18 - 25 x 28	38.0	41.5	15.0	16.5	355	495
18 - 30 x 32	44.0	47.0	17.5	18.5	380	570

PROD. NO	CONTENTS
1806	6x7, 8x9, 10x11, 12x13, 14x15, 16x17
1808	6x7, 8x9, 10x11, 12x13, 14x15, 16x17, 18x19, 20x22
1810	6x7, 8x9, 10x11, 12x13, 14x15, 16x17, 18x19, 20x22, 21x23, 24x27
1812	6x7, 8x9, 10x11, 12x13, 14x15, 16x17, 18x19, 20x22, 21x23, 24x27, 25x28, 30x32

TAPARIA TOOLS LTD.



Head Office : 423 / 424, A-2, Shah & Nahar, Lower Parel (W), Mumbai - 400 013. & : 2493 8646 - 50
 Fax : 91-22-2495 3230. • E-mail : sales@tapariatools.com • Web Site : http://www.tapariatools.com
 Works : 52-B, M. I. D. C., Satpur, Nashik - 422 007. & : 2350 317 / 318 / 418 • Fax : 0253-2350740



An ISO-9001 Company

TAPARIA® TAPARIA® TAPARIA® TAPARIA® TAPARIA®



TAPARIA TOOLS LTD.

AN ISO-9001 COMPANY



SPIRIT LEVEL

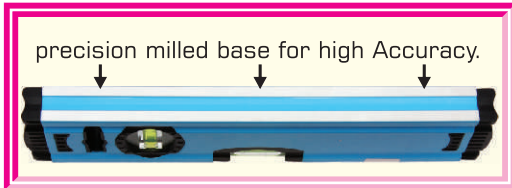

- ★ TAPARIA Spirit levels have precision milled base for high Accuracy.
- ★ TAPARIA Spirit levels have a solid Spirit bulb which does not break easily.
- ★ The spirit of TAPARIA Levels is special and lasts for a long time.
- ★ The Aluminum frame is strong and precision extruded which increases accuracy and strength of the Spirit levels.
- ★ Rubber moulding is provided on the sides of the spirit levels to prevent damage to the body of the spirit levels.
- ★ Available in two ranges i.e. 1mm/meter accuracy and 0.50mm/meter accuracy to cater to regular and high precision requirements.



1mm / mtr. Accuracy

PRODUCT NO.	SIZE IN cm's	A	B	C	WEIGHT GRAMS
SL 10 12 (WITHOUT MAGNET)	30 cm	300	50	20	165
SL 10 16 (WITHOUT MAGNET)	40 cm	400	50	20	210
SL 10 20 (WITHOUT MAGNET)	50 cm	500	50	20	245
SL 10 24 (WITHOUT MAGNET)	60 cm	600	50	20	295
SL 10 36 (WITHOUT MAGNET)	90 cm	900	50	20	415
SL 10 48 (WITHOUT MAGNET)	120 cm	1200	50	20	555
SLM 10 12 (WITH MAGNET)	30 cm	300	50	20	235
SLM 10 16 (WITH MAGNET)	40 cm	400	50	20	280
SLM 10 20 (WITH MAGNET)	50 cm	500	50	20	315
SLM 10 24 (WITH MAGNET)	60 cm	600	50	20	365
SLM 10 36 (WITH MAGNET)	90 cm	900	50	20	495

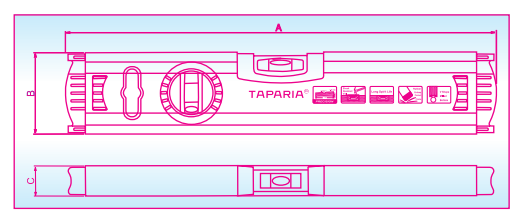

0.5 mm / mtr. Accuracy

PRODUCT NO.	SIZE IN cm's	A	B	C	WEIGHT GRAMS
SL 05 12 (WITHOUT MAGNET)	30 cm	300	57	22	190
SL 05 24 (WITHOUT MAGNET)	60 cm	600	57	22	335
SLM 05 12 (WITH MAGNET)	30 cm	300	57	22	240
SLM 05 24 (WITH MAGNET)	60 cm	600	57	22	395

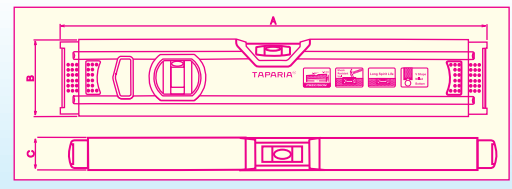

TOOLS TROLLY

- ★ Reinforced double wall frame with single piece casting enables high strength and long life.
- ★ High quality ball bearing slides enable smooth drawer opening.
- ★ Rear locking system avoids opening of the drawers when the
- ★ Tools Trolley is being moved The Castors are smooth, strong & chemical resistant and have a load capacity of upto 550 lbs.
- ★ Superior Powder Coating on the cabinets gives extra rust protection and good looks.
- ★ Tools Trollies are available in 2 models i.e. ToolsTrolley having 5 drawers & Tools Trolley having 7 drawers.

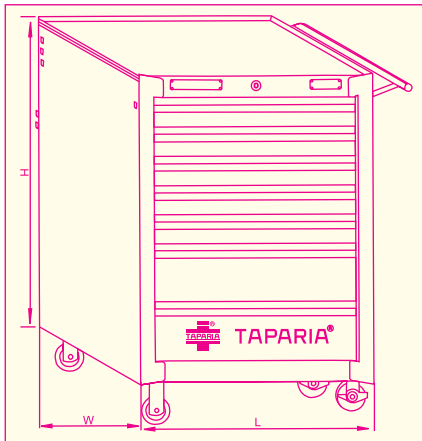

5 Drawers



7 Drawers

PRODUCT NO.	H	W	L	WEIGHT
TTB 5	780	520	749	40.7 Kg.
TTB 7	935	520	749	55.0 Kg.

TAPARIA TOOLS LTD.



Head Office : 423 / 424, A-2, Shah & Nahar, Lower Parel (W), Mumbai - 400 013. & : 2493 8646 - 50
Fax : 91-22-2495 3230. • **E-mail :** sales@tapariatools.com • **Web Site :** http://www.tapariatools.com
Works : 52-B, M. I. D. C., Satpur, Nashik - 422 007. & : 2350 317 / 318 / 418 • **Fax :** 0253-2350740



An ISO-9001 Company

TAPARIA® TAPARIA® TAPARIA® TAPARIA® TAPARIA®



TAPARIA TOOLS LTD.

AN ISO - 9001 COMPANY



TORQUE WRENCHES (PROFESSIONAL)

- * New attractive design.
- * Easier torque settings.
- * Ergonomic handles for fine gripping.
- * Quick releasing and shifting cam mechanism.
- * The torque wrench is made up of high grade steel to withstand maximum fatigue, wear and tear.
- * Clear and distinct scaling on torque wrench in N-m, Lb-ft and Kgf-m.



TORQUE WRENCHES RATCHET TYPE PROFESSIONAL RANGE

Product No.	Specification			
	Dr.	Lb Ft	Kgf.m	N.m
TPWR 25	3/8	4-18	0.5-2.5	5-25
TPWR 50	1/2	8-44	1-6	10-60
TPWR 100	1/2	15-88	2-12	20-120
TPWR 160	1/2	30-162	4-22	40-220
TPWR 250	1/2	45-243	6.1-33.5	60-330

TORQUE WRENCHES PROFESSIONAL RANGE

Product No.	Specification			
	Dr.	Lb Ft	Kgf.m	N.m
TWP 10	3/8	2-8	0.3-1.2	2.5-11
TWP 25	3/8	4-24	0.5-3.4	5-33
TWP 50	1/2	10-50	1.2-7	12-68
TWP 100	1/2	20-100	3-14	25-135
TWP 160	1/2	40-160	5-23	50-225
TWP 250	1/2	50-250	7-35	70-330
TWP 400	3/4	100-410	14-57	140-560

TORQUE WRENCHES STANDARD

Product No.	Specification			
	Dr.	Lb Ft	Kgf.m	N.m
TW 10	3/8	2-10	0.3-1.4	3-14
TW 25	3/8	5-25	0.5-3.5	5-35
TW 50	1/2	10-50	1.4-7	14-68
TW 100	1/2	20-100	3-14	25-135
TW 160	1/2	35-160	5-22	50-220
TW 250	1/2	50-250	7-35	70-340
TW 400	3/4	100-400	14-56	135-540
TW 500	3/4	100-500	14-70	135-675
TW 750	3/4	350-750	49-105	475-1015
TW 1000	1	400-1000	55-140	540-1380
TW 1400	1	750-1400	105-196	1000-1900
TW 2000	1	1000-2000	135-275	1350-2700

TORQUE WRENCHES RATCHET TYPE

Product No.	Specification			
	Dr.	Lb Ft	Kgf.m	N.m
TWR 10	3/8	2-10	0.3-1.4	3-14
TWR 400	3/4	100-400	14-56	135-540



TAPARIA TOOLS LTD.

423 / 424, A-2, Shah & Nahar, Lower Parel (W), Mumbai - 400 013 (MH). ☎ : (022) 6147 8646.
 E-mail : htaparia@tapariatools.com, sales@tapariatools.com • Web Site : http://www.tapariatools.com
Works : 52, M.I.D.C, Satpur, Nashik - 422 007 (MH), ☎ : (0253) 2350 317 / 18 / 418.
 E-mail : nashik@tapariatools.com. C.I.N. No. : L99999MH1965PLC013392



TAPARIA® TAPARIA® TAPARIA® TAPARIA® TAPARIA®



TAPARIA TOOLS LTD.
AN ISO - 9001 COMPANY



VDE PLIERS



- * Made from high grade alloy steel to give best performance.
- * VDE approved sleeve for operating at high voltages.
- * Fully insulated with High quality sleeves withstand up to 1000V AC.
- * Sleeves ensure comfortable and firm grip to users.
- * Precise wire cutting ability for soft and hard wire material.
- * Manufactured according to IEC60900:2018.

Combination Pliers

Product No.	A	B	T	W	L	Weight Grams
VDECP - 6	33.5	12	9.0	24.5	170	210
VDECP - 8	41	15	10.3	29	210	340

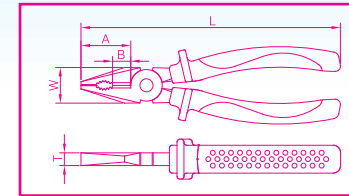

Long Nose Pliers

Product No.	A	B	T	T1	W	L	Weight Grams
VDELN - 6	48.5	12	9.3	3	16	170	155

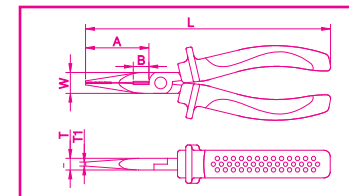

Side Cutting Pliers

Product No.	A	B	T	W	L	Weight Grams
VDESC - 6	--	24	11.5	21	170	210

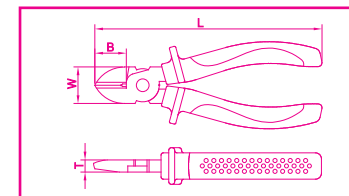

End Wire Stripping Pliers

Product No.	A	B	T	W	L	Weight Grams
VDEWS - 6	38	--	8.8	19	172	185

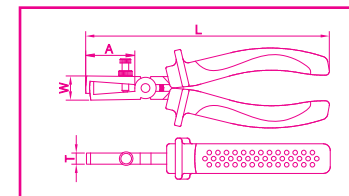

TAPARIA TOOLS LTD.



423 / 424, A-2, Shah & Nahar, Lower Parel (W), Mumbai - 400 013 (MH). ☎ : (022) 6147 8646.
E-mail : htaparia@tapariatools.com, sales@tapariatools.com • Web Site : <http://www.tapariatools.com>
Works : 52, M.I.D.C, Satpur, Nashik - 422 007 (MH), ☎ : (0253) 2350 317 / 18 / 418.
E-mail : nashik@tapariatools.com. C.I.N. No. : L99999MH1965PLC013392



TAPARIA® TAPARIA® TAPARIA® TAPARIA® TAPARIA®